

Assembly instruction

120 MIN

APPROXIMATE ASSEMBLY TIME

2 PERSON ASSEMBLY



FLOOR AREA
3.0M x 3.0M



REQUIRED ASSEMBLY SPACE

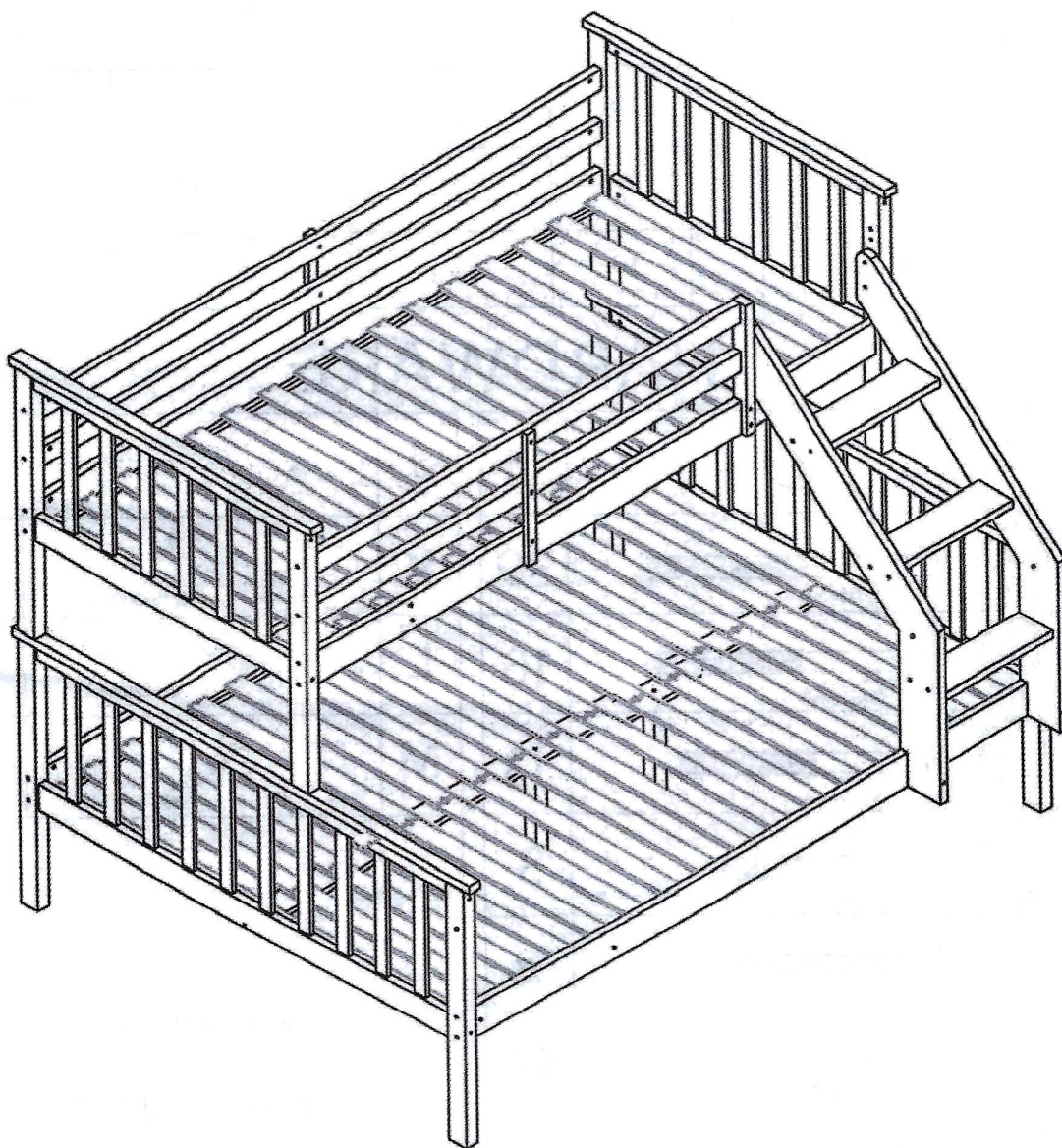





PART





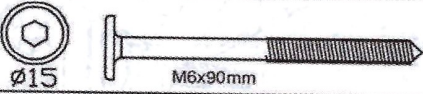
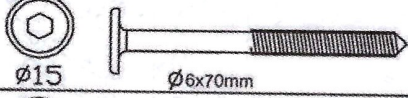
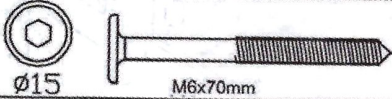

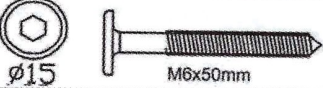
| Part | Quantity |
|------|----------|
| 1 | 1 |
| 2 | 1 |
| 3 | 1 |
| 4 | 1 |
| 5 | 1 |
| 6 | 1 |
| 7 | 1 |
| 8 | 2 |
| 9 | 2 |

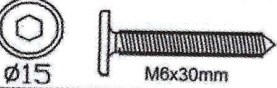
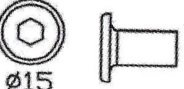
| Part | Quantity |
|------|----------|
| 10 | 2 |
| 11 | 2 |
| 12 | 1 |
| 13 | 1 |
| 14 | 1 |
| 15 | 1 |
| 16 | 1 |
| 17 | 1 |
| 18 | 2 |

| Part | Quantity |
|------|----------|
| 19 | 2 |
| 20 | 2 |
| 21 | 1 |
| 22 | 1 |
| 23 | 1 |
| 24 | 2 |
| 25 | 2 |
| 26 | 3 |
| | |

HARDWARE

| | | |
|---|--|----|
| A |  | 11 |
| B |  Ø15 M6x90mm | 39 |
| C |  Ø15 Ø6x70mm | 16 |
| D |  Ø15 M6x70mm | 13 |
| E |  Ø15 M6x60mm | 3 |
| F |  Ø15 M6x50mm | 2 |
| G |  | 40 |
| H |  Ø15 M6x30mm | 6 |
| I |  Ø15 | 11 |

| | | |
|---|---|----|
| J |  | 2 |
| K |  Ø12x80mm | 4 |
| L |  Ø8x30mm | 46 |
| M |  | 66 |
| not included | | |
|  | | |
|  | | |

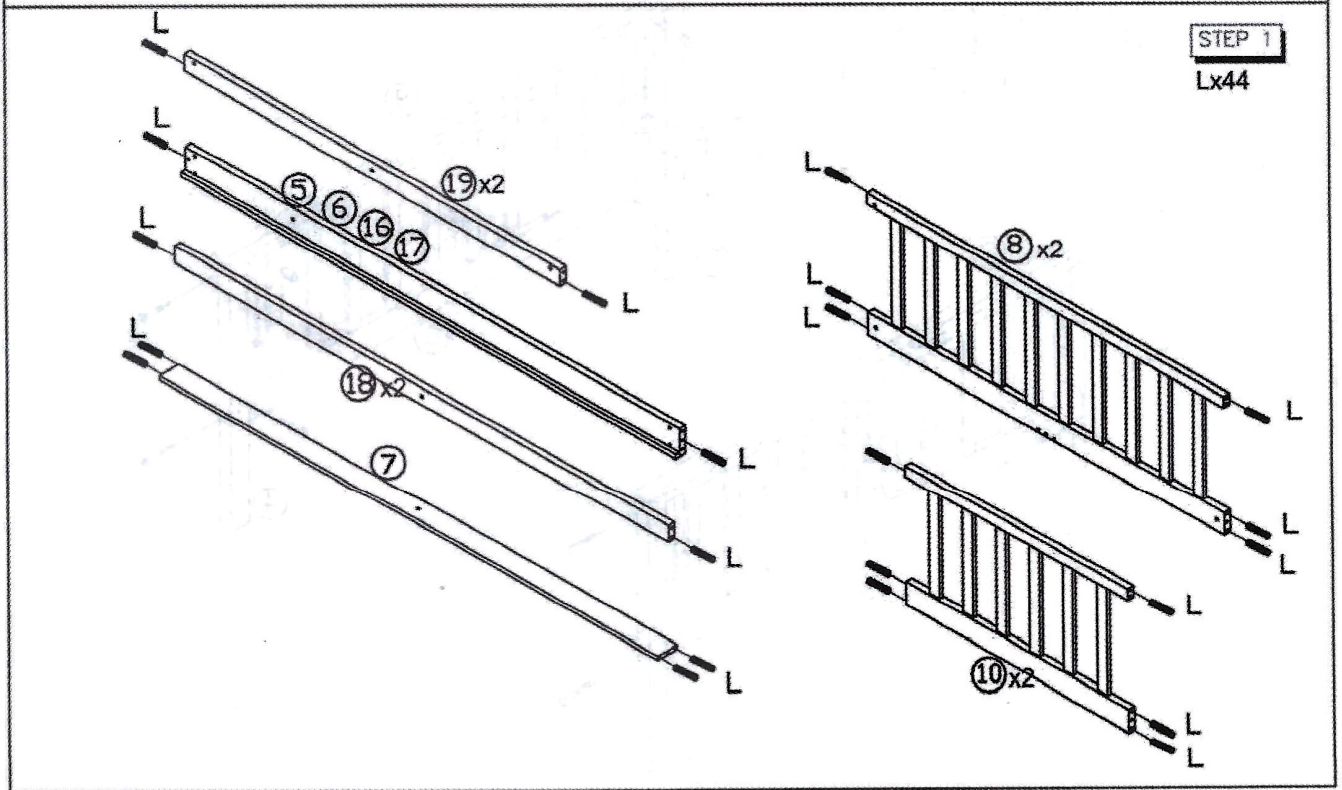
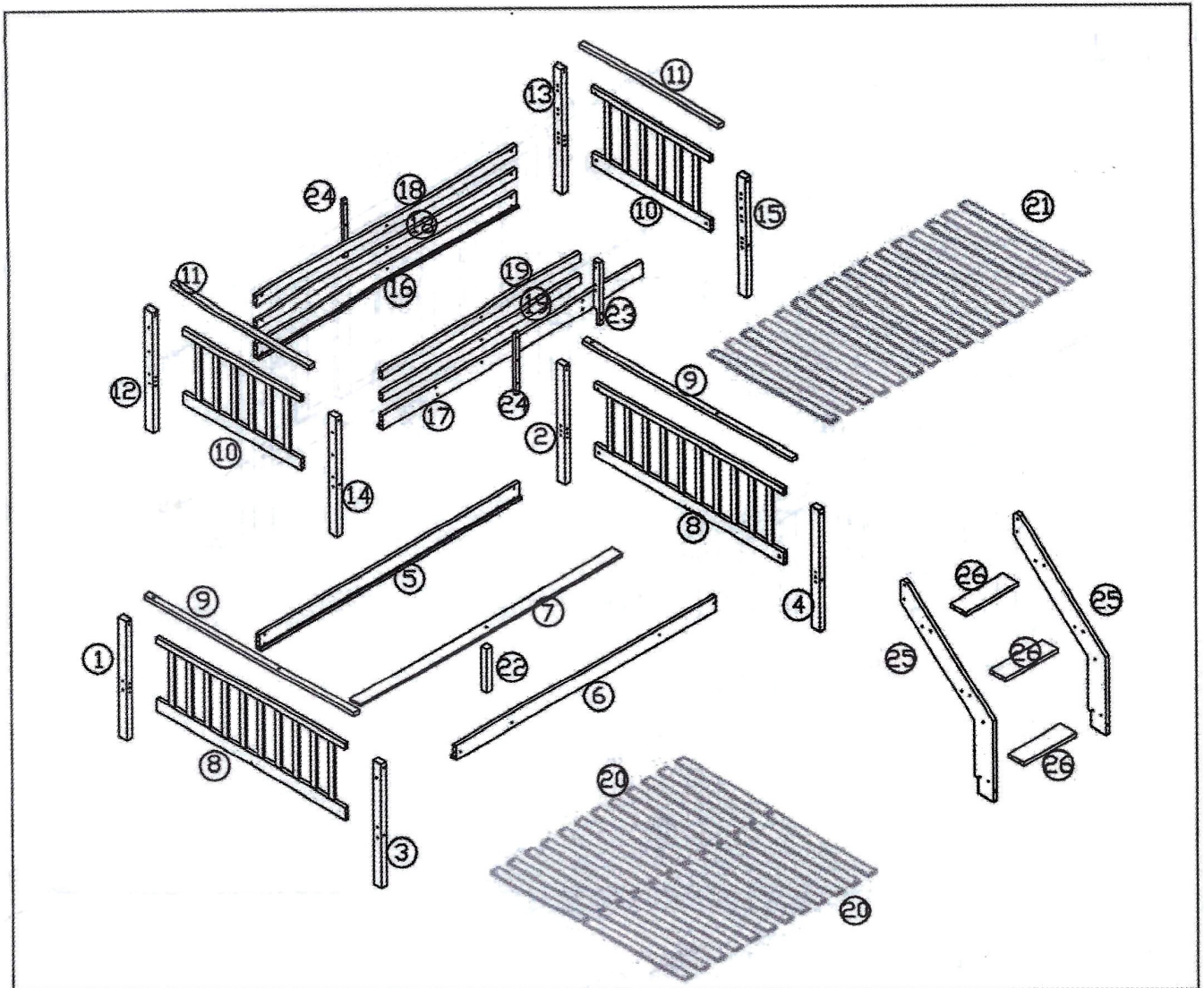

STEP 2

Bx8

Dx6

Gx8

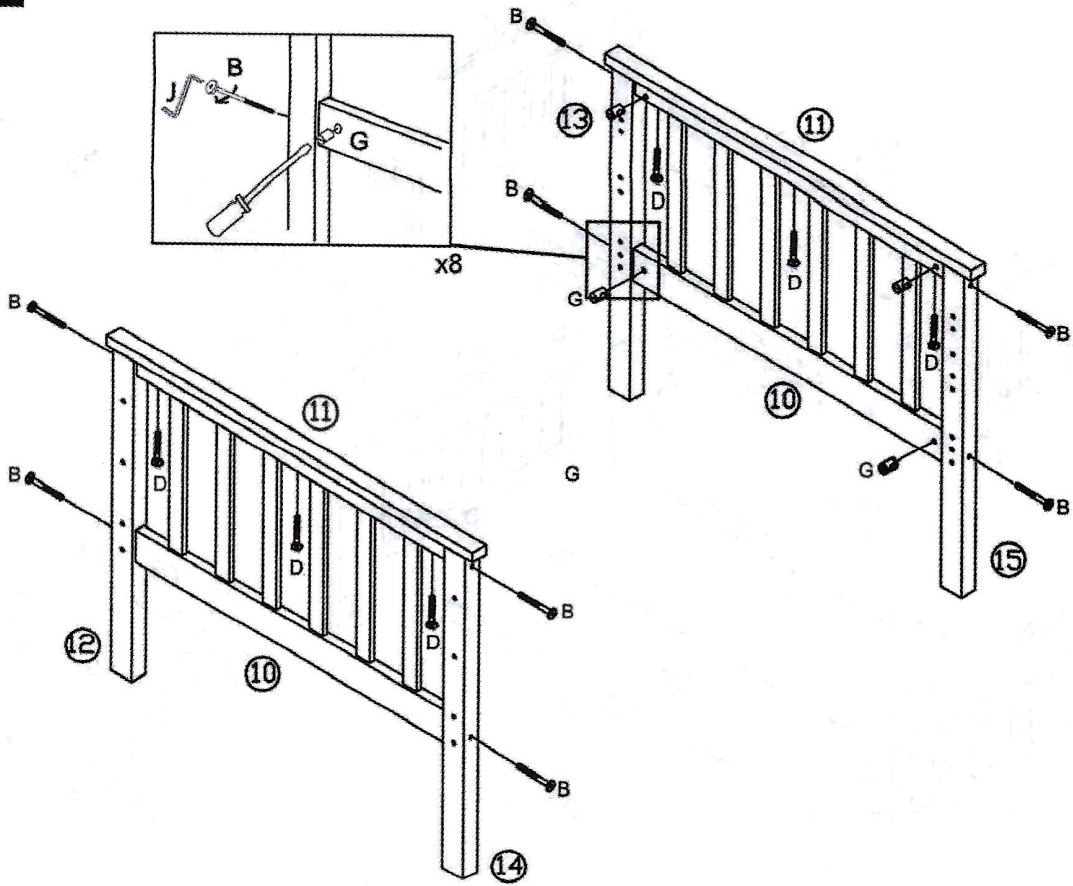

STEP 3

Bx8

Dx6

Gx8

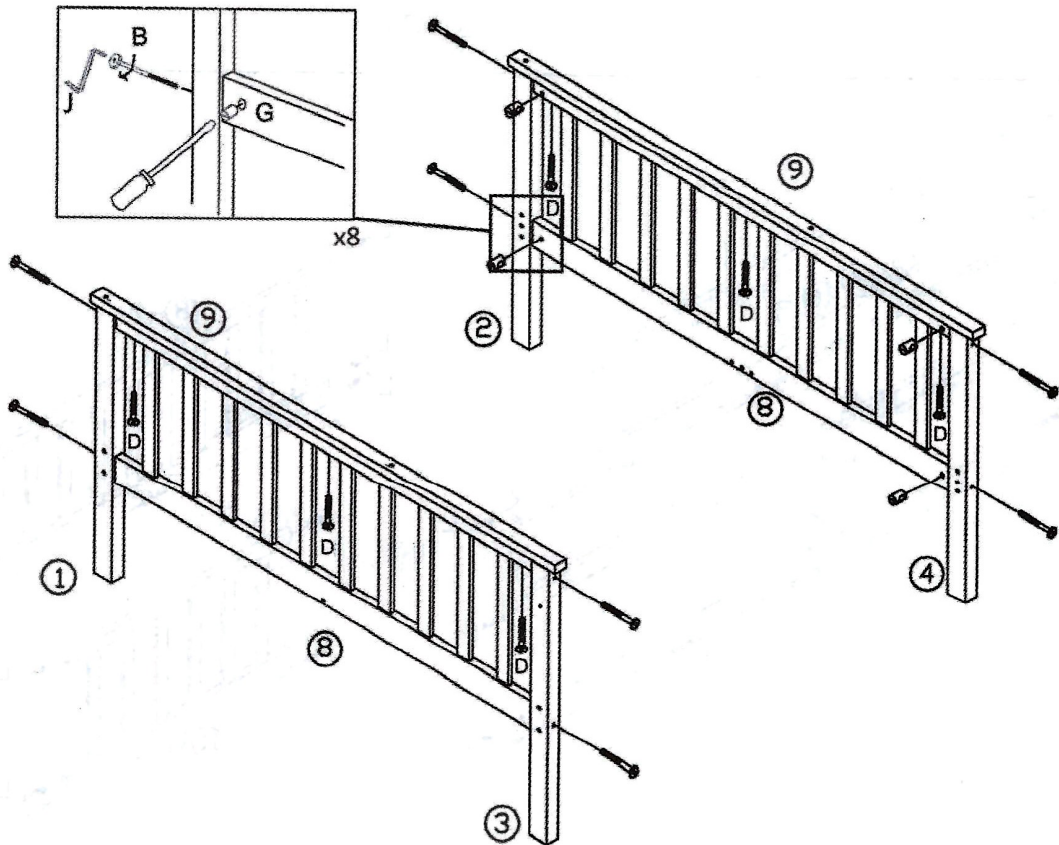

STEP 4

- Bx14
- Gx15
- Dx1
- Fx2
- Hx6
- IX8

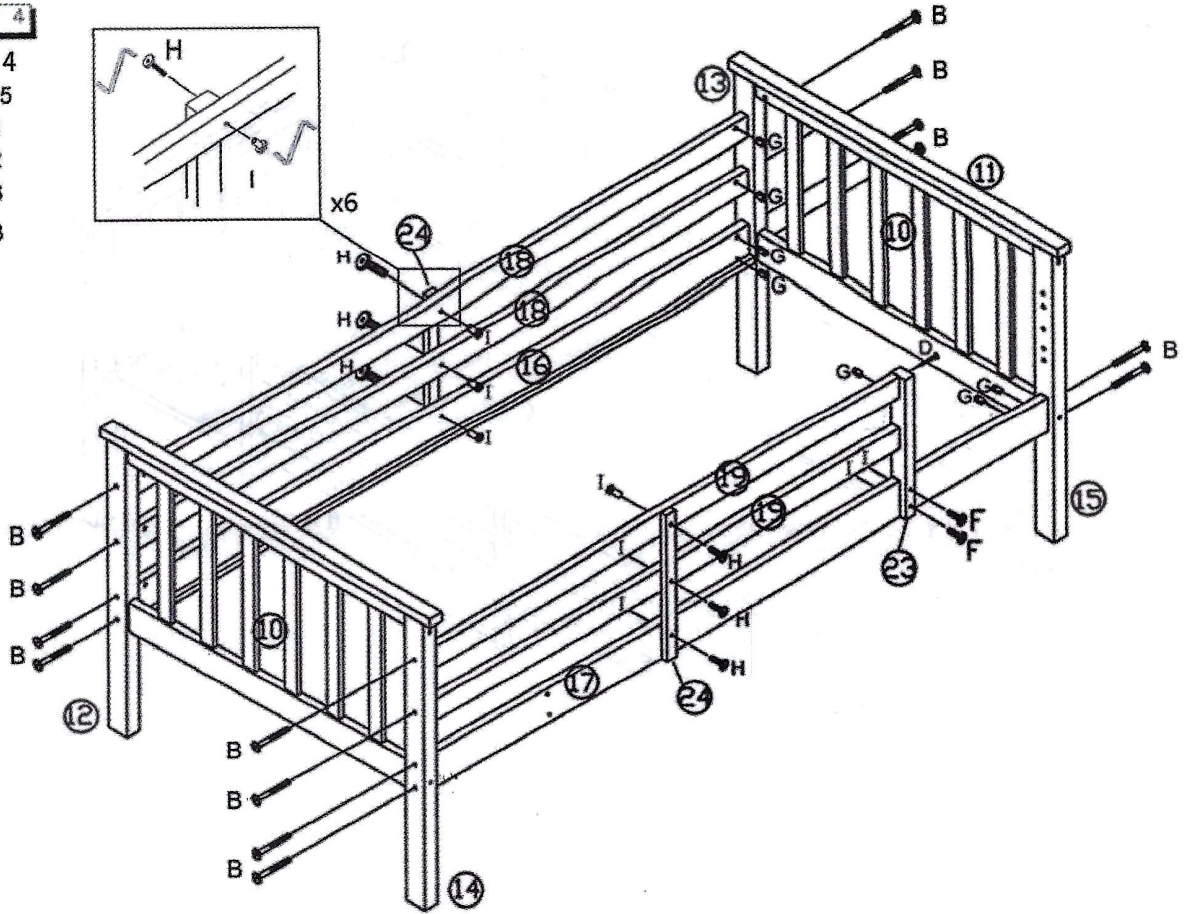
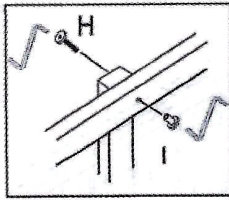

STEP 5

- Bx8
- Cx4
- Gx8

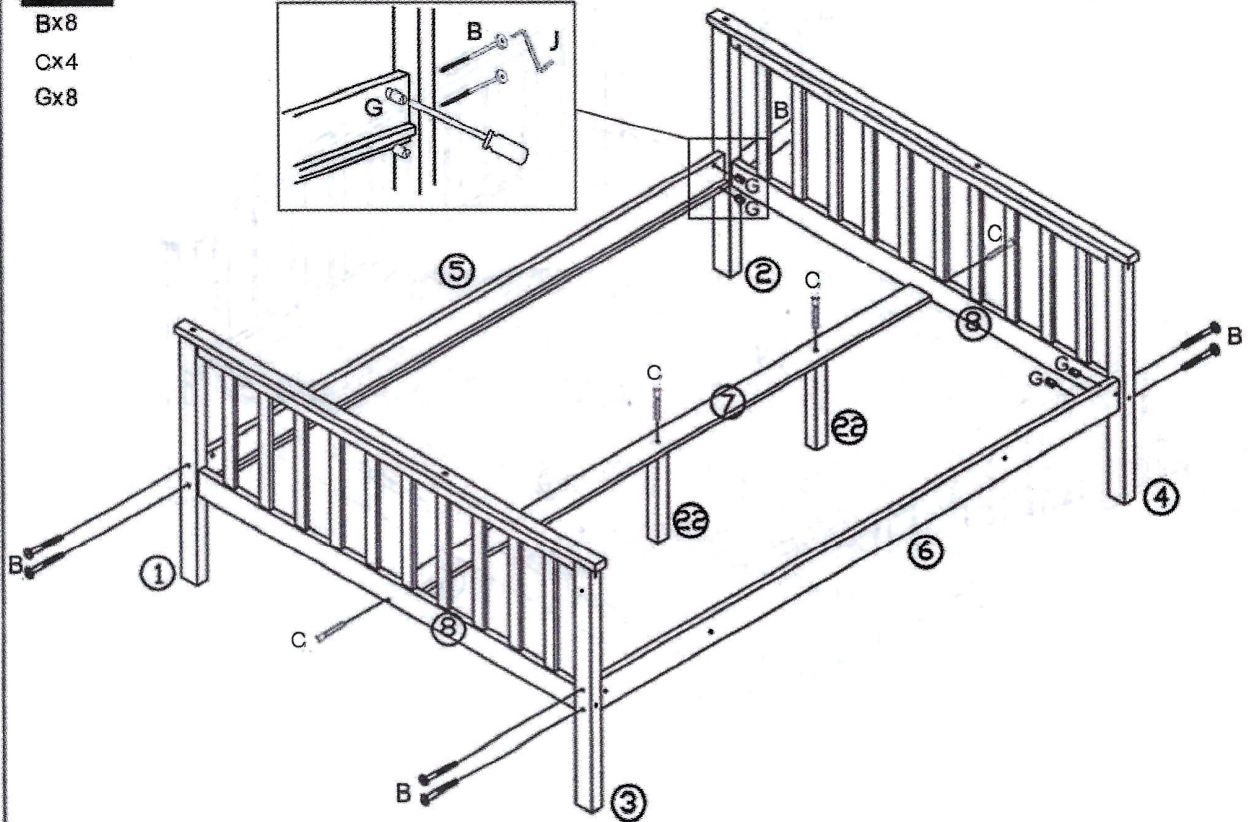
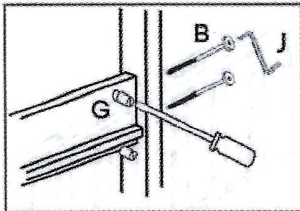

STEP 6

MX30

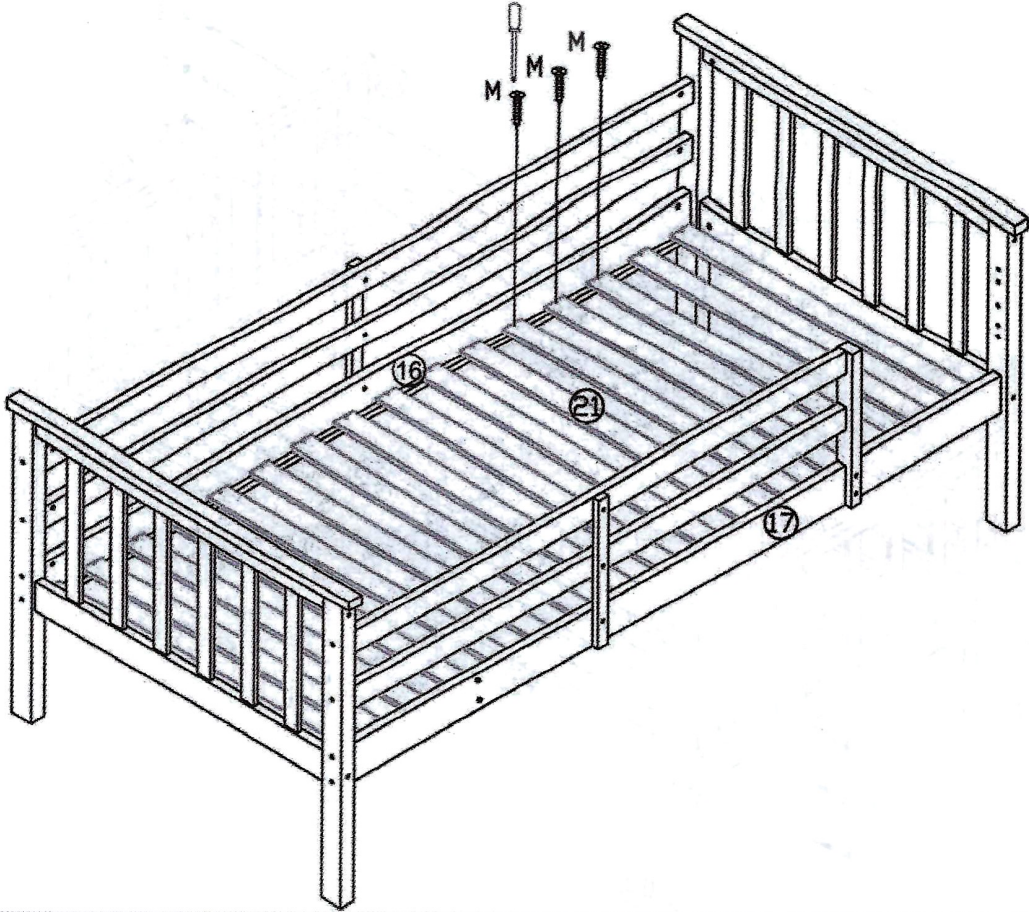

STEP 7

Mx30

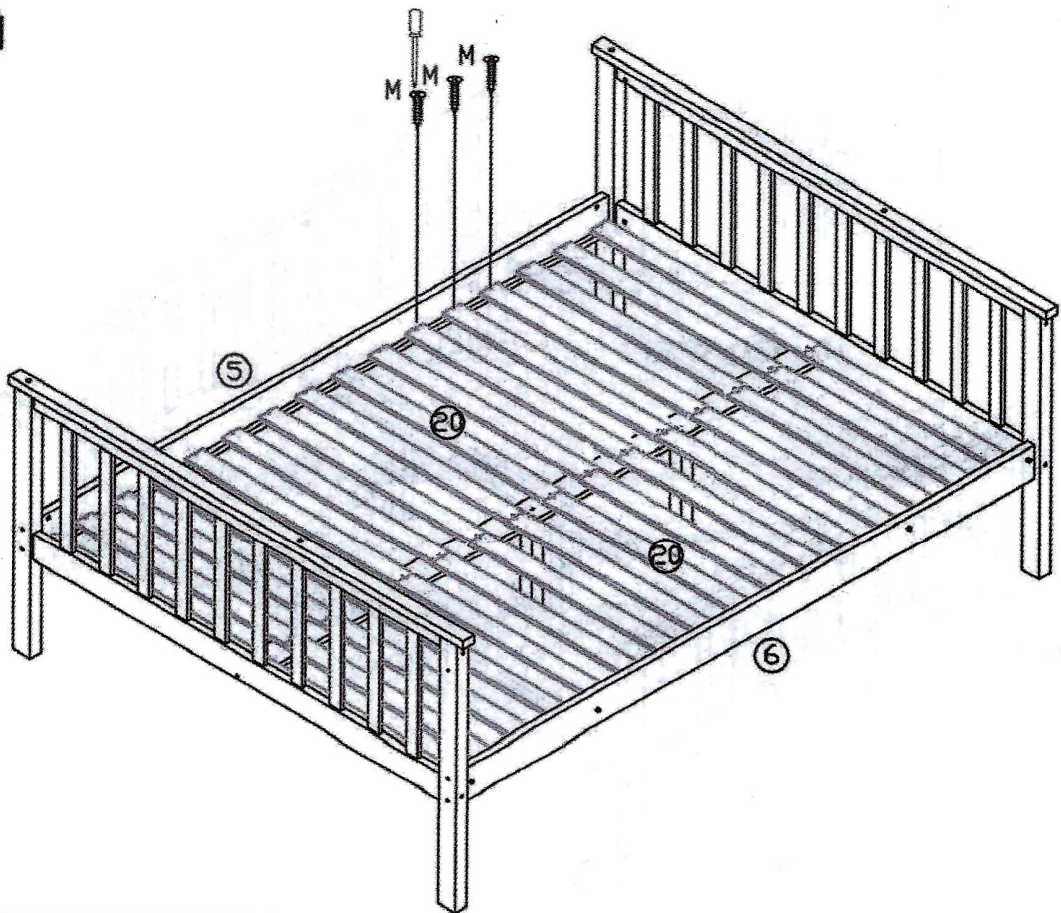

STEP 8

Kx4

Mx6

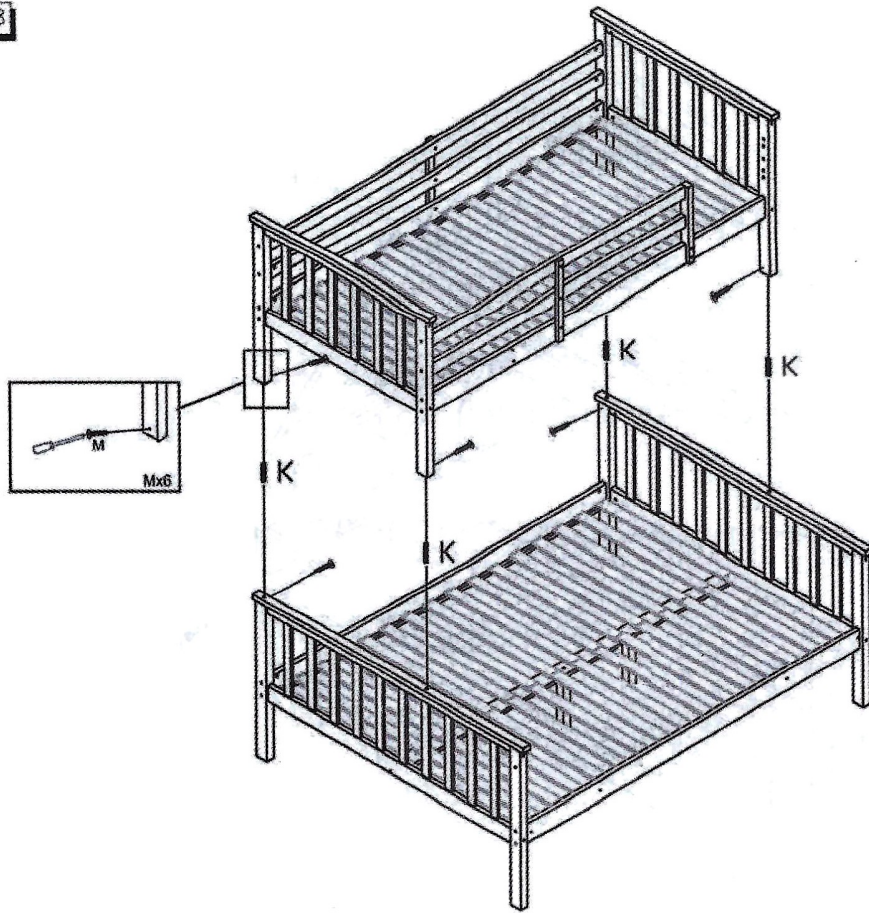

STEP 9

Lx2

Cx12

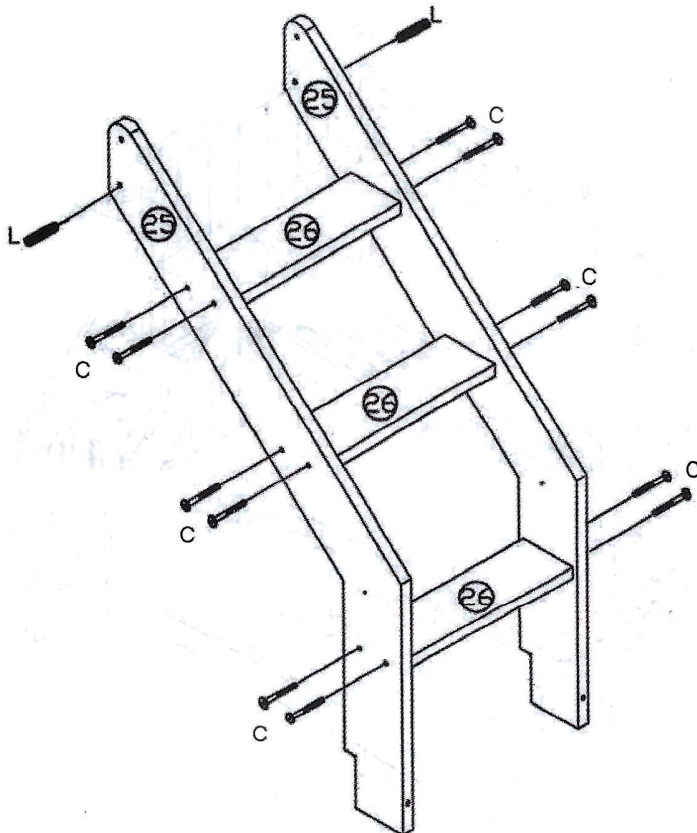

STEP 10

- Bx1
- Dx1
- Ex2
- Gx1
- Ix3

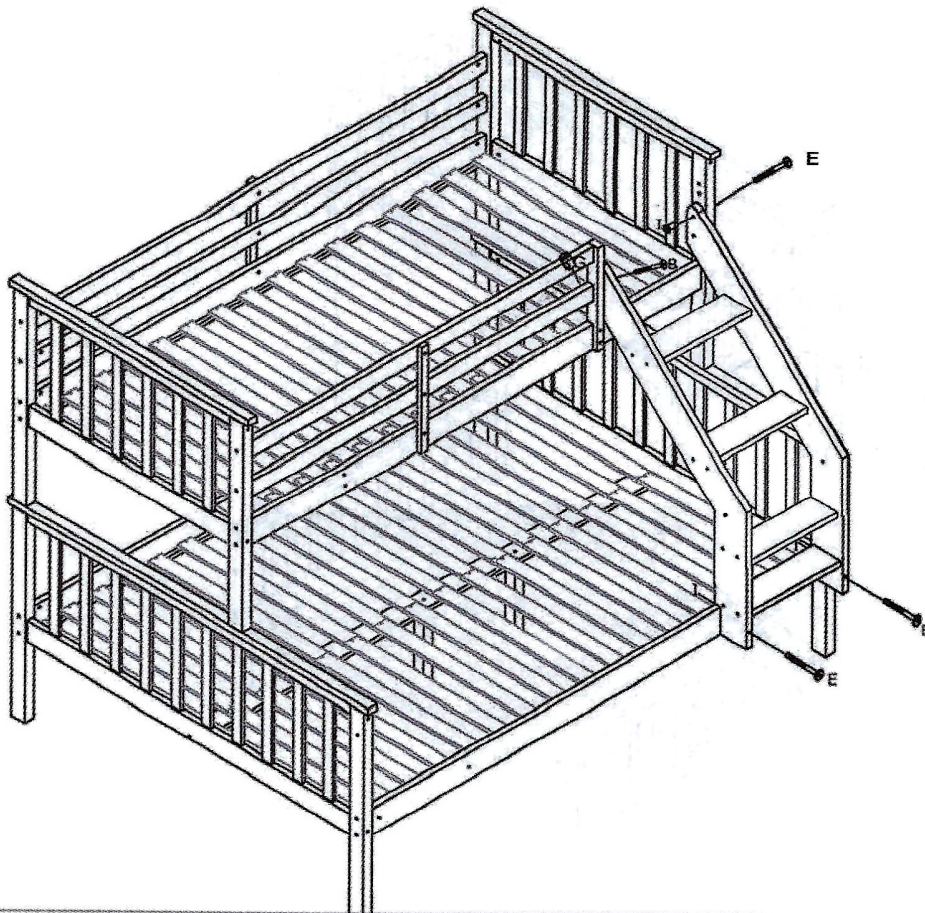

STEP 11

- Ax11

