

ASSEMBLY INSTRUCTIONS

ITEM # : C8636D-D4WF9XLGX
DESCRIPTION: ROUND DINING TABLE

* Thank you for purchasing this quality product.
* Read instruction carefully prior to assembly!
* Unit should be assembled by two or more people!
* Remove all components from pack and place product down on soft surface such as carpet or cloth to prevent scratching the finish. Identify and count all parts as specified below.
* Do not tighten bolts until assembly is complete.

* Gracias por comprar este producto de calidad.
* Lea las instrucciones cuidadosamente antes del montaje!
* La unidad debe ser montada por dos o más personas!
* Retire todos los componentes del paquete y coloque el producto sobre una superficie blanda, como alfombras o telas, para evitar arañazos en el acabado. Identifique y cuente todas las piezas como se especifica a continuación.
* No apriete los pernos hasta que el montaje esté completo!

* Merci d' avoir acheté ce produit de qualité!
* Lisez attentivement les instructions avant le montage!
* L' unité doit être assemblée par deux personnes ou plus!
* Retirez tous les composants de l'emballage et placez le produit sur la surface molle comme le tapis ou le tissu pour éviter de gratter la finition. Identifiez et comptez toutes les pièces telles que spécifiées ci-dessous.
* Ne pas serrer les boulons jusqu'à ce que l'assemblage soit terminé.

"PART LISTS"

"HARDWARE LISTS"

No.	DESC	SKETCH	QTY	No.	OUTLOOK	SIZE	QTY
A	TABLE TOP		1pc	1		Bolt (5/16"x1-1/2")	25pcs
B	TABLE LEGS		4pcs	2		M4x50mm	4pcs
C	TABLE BASE PANEL		4pcs	3		Allen Key 58x23x4mm	1pc
D	TABLE TOP STRETCHER		1pc	ATTENTION: SCREW DRIVER NOT INCLUDED			
E	TABLE BOTTOM STRETCHER		1pc				

STEP 1 (x4)

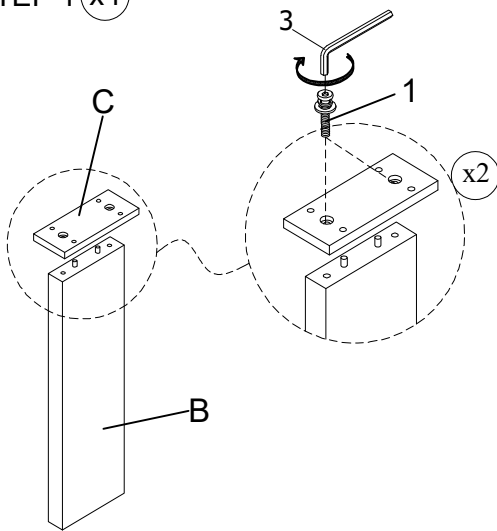

STEP 2

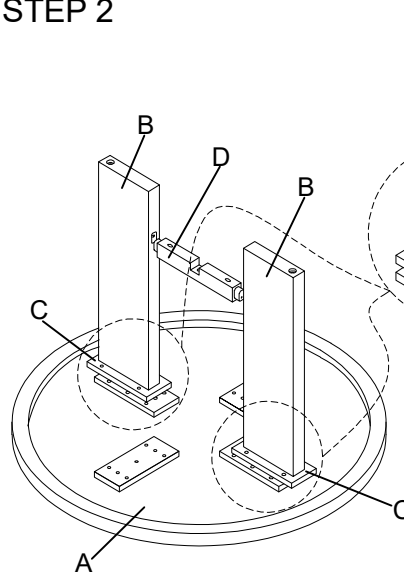

STEP 3

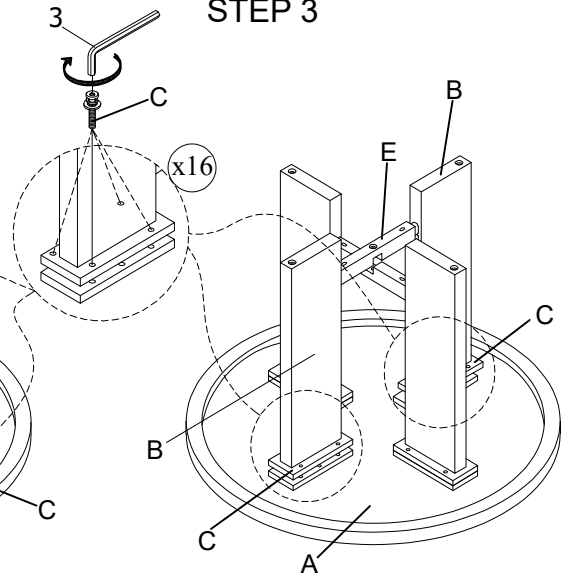

STEP 4

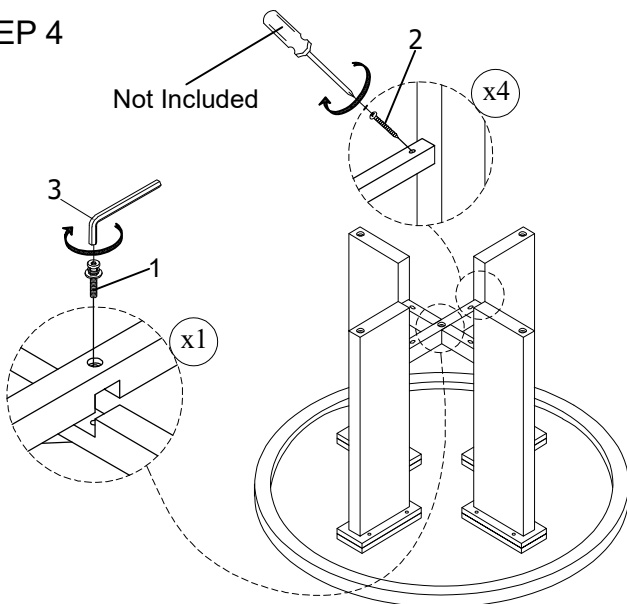

STEP 5

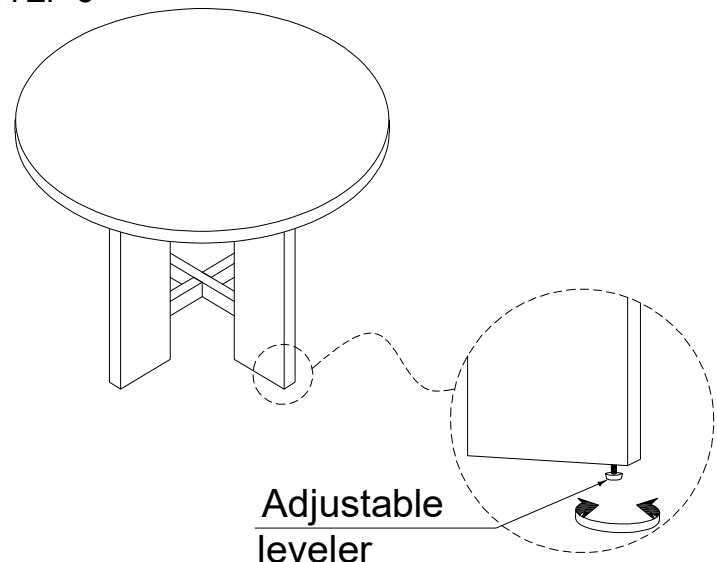

Cleaning instructions: Clean using soft cloth.

MADE IN VIETNAM

ASSEMBLY INSTRUCTIONS

ITEM # : C8636D-D4WF9XLGX



DESCRIPTION: SIDE CHAIR

* Thank you for purchasing this quality product.
 * Read instruction carefully prior to assembly!
 * Unit should be assembled by two or more people!
 * Remove all components from pack and place product down on soft surface such as carpet or cloth to prevent scratching the finish. Identify and count all parts as specified below.
 * Do not tighten bolts until assembly is complete.



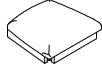

* Gracias por comprar este producto de calidad.
 * Lea las instrucciones cuidadosamente antes del montaje!
 * La unidad debe ser montada por dos o más personas!
 * Retire todos los componentes del paquete y coloque el producto sobre una superficie blanda, como alfombras o telas, para evitar arañazos en el acabado. Identifique y cuente todas las piezas como se especifica a continuación.
 * No apriete los pernos hasta que el montaje esté completo!

* Merci d' avoir acheté ce produit de qualité!
 * Lisez attentivement les instructions avant le montage!
 * L' unité doit être assemblée par deux personnes ou plus!
 * Retirez tous les composants de l'emballage et placez le produit sur la surface molle comme le tapis ou le tissu pour éviter de gratter la finition. Identifiez et comptez toutes les pièces telles que spécifiées ci-dessous.
 * Ne pas serrer les boulons jusqu'à ce que l'assemblage soit terminé.

"PART LISTS"

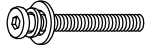
No.	DESC	SKETCH	QTY
A	CHAIR BACK		1pc
B	CUSHION SEAT W/FRAME		1pc
C	CHAIR LEGS		2pcs

"HARDWARE LISTS"

No.	OUTLOOK	SIZE	QTY
1		Bolt (1/4"x3-1/8")	4pcs
2		Bolt (1/4"x2-3/8")	4pcs
3		Bolt (1/4"x1-1/2")	2pcs
4		Allen Key 58x23x4mm	1pc

STEP 1

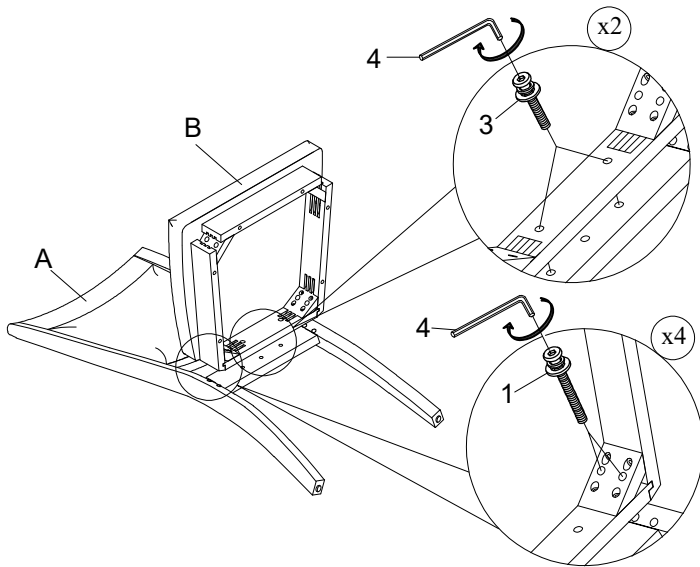

STEP 2

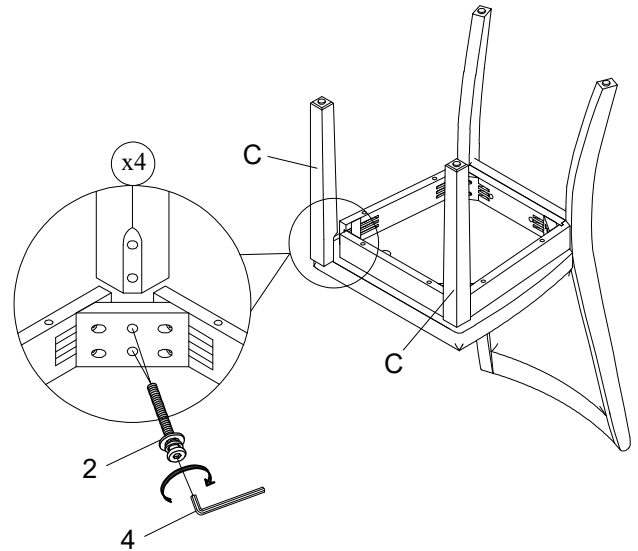

STEP 3

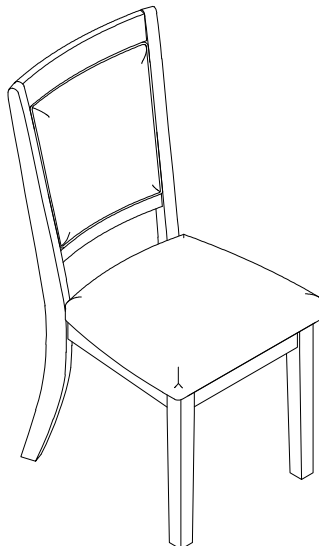

Cleaning instructions: Clean using soft cloth.

MADE IN VIETNAM