







# Assembly Instruction



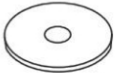

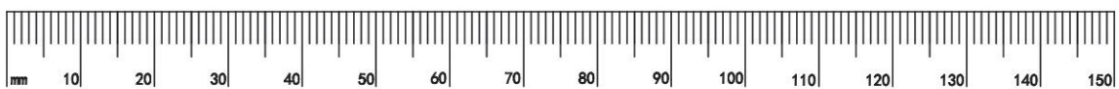

<b>A X1</b> 	<b>B X1</b> 	<b>C X1</b> 	<b>D X5</b>  Ø 6X18X1.5
<b>E X1</b>  M6X20	<b>F X4</b>  M6x40mm	<b>G X1</b>  M5	

2-1

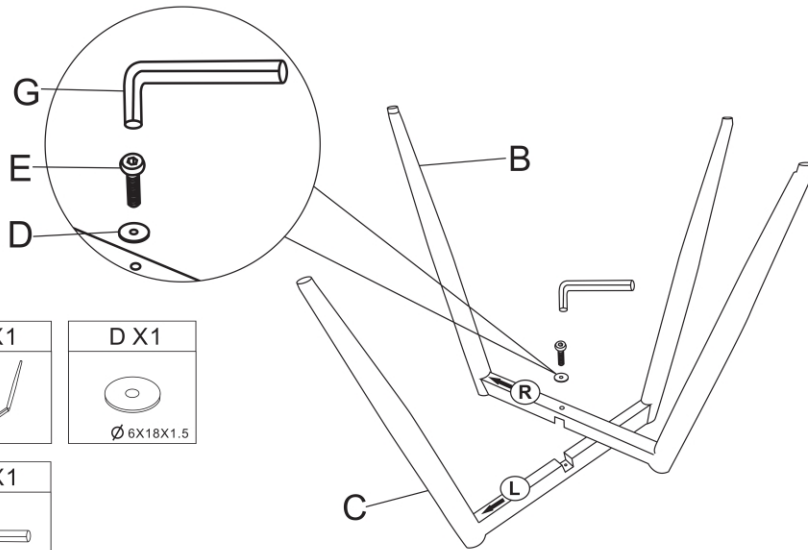



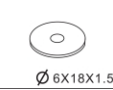

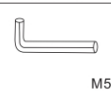
# 1

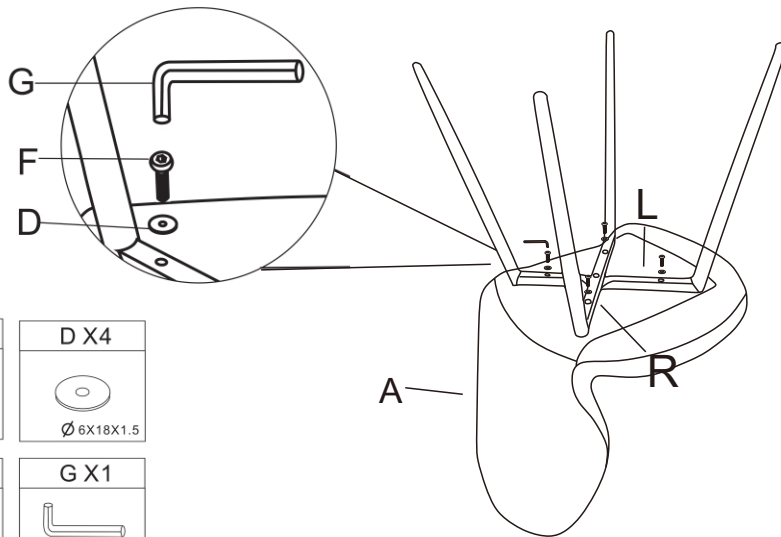

<b>B X1</b> 	<b>C X1</b> 	<b>D X1</b>  Ø6X18X1.5
<b>E X1</b>  M6X20	<b>G X1</b>  M5	

# 2

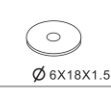

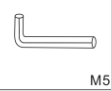
<b>A X1</b> 	<b>D X4</b>  Ø6X18X1.5
<b>F X4</b>  M6x40mm	<b>G X1</b>  M5

# 3

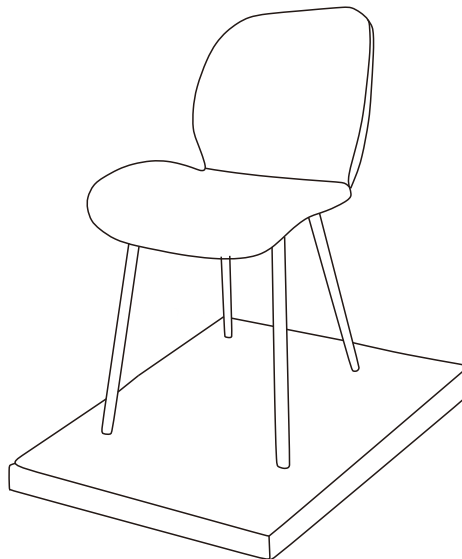

2-2

