

ASSEMBLY INSTRUCTIONS

Important Safety Instructions:

- Please read all instructions before beginning assembly
- Please make sure receive all the parcels to start the assembly
- For your safety and convenience, assembly by two people is recommended
- Use the parts and hardware lists to identify and separate each of the components included
- Save all packing materials until assembly is completed to avoid the accidental discarding of smaller parts or hardware

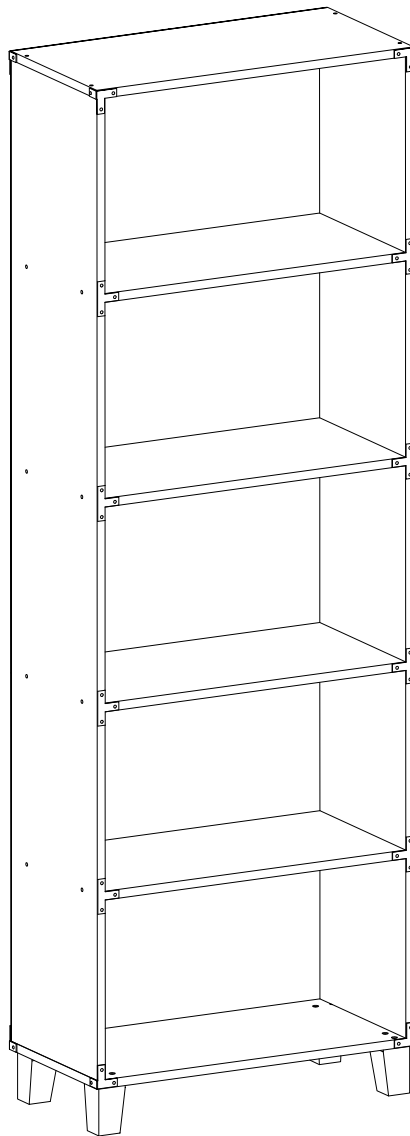





THANK YOU FOR PURCHASING

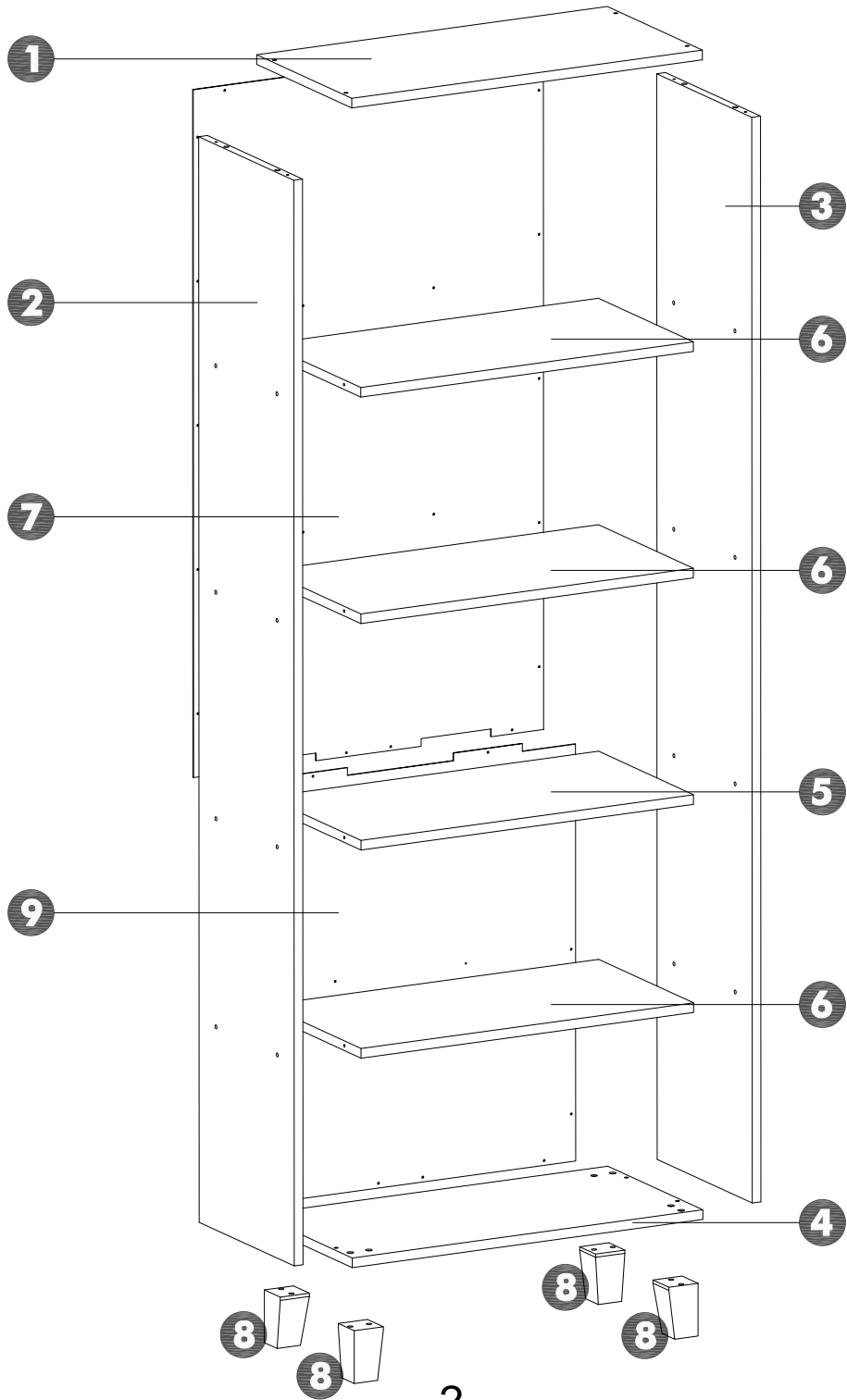

PARTS LIST

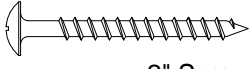
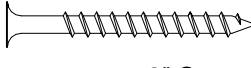
- ① X1 ② X1 ③ X1 ④ X1 ⑤ X1
- ⑥ X3 ⑦ X1 ⑧ X4 ⑨ X1

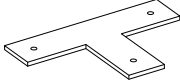
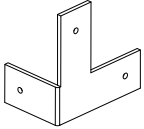
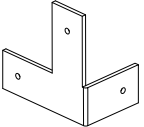

HARDWARE LIST

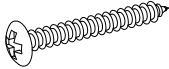
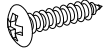
Name	Part	Qty.	Spare
A	 2" Screw	20	1
B	 2" Screw	12	
C		4	1
D	 3/4" Nail	36	2
E		8	
F		4	
G		4	
H		48	2

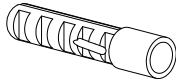
Name	Part	Qty.	Spare
U1		1	
U2		1	
U3		1	
U4		1	

STEP 1

C x4pcs

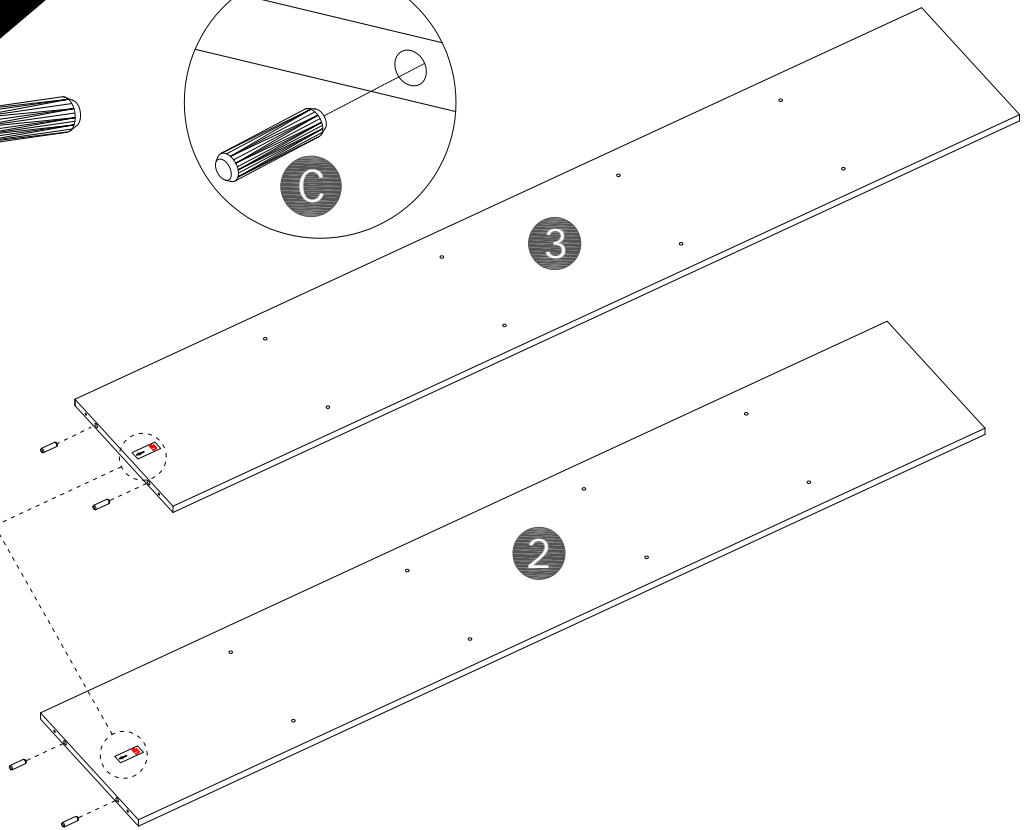
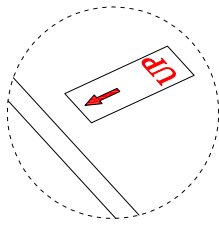
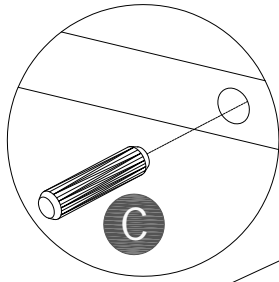

STEP 2

A x8pcs

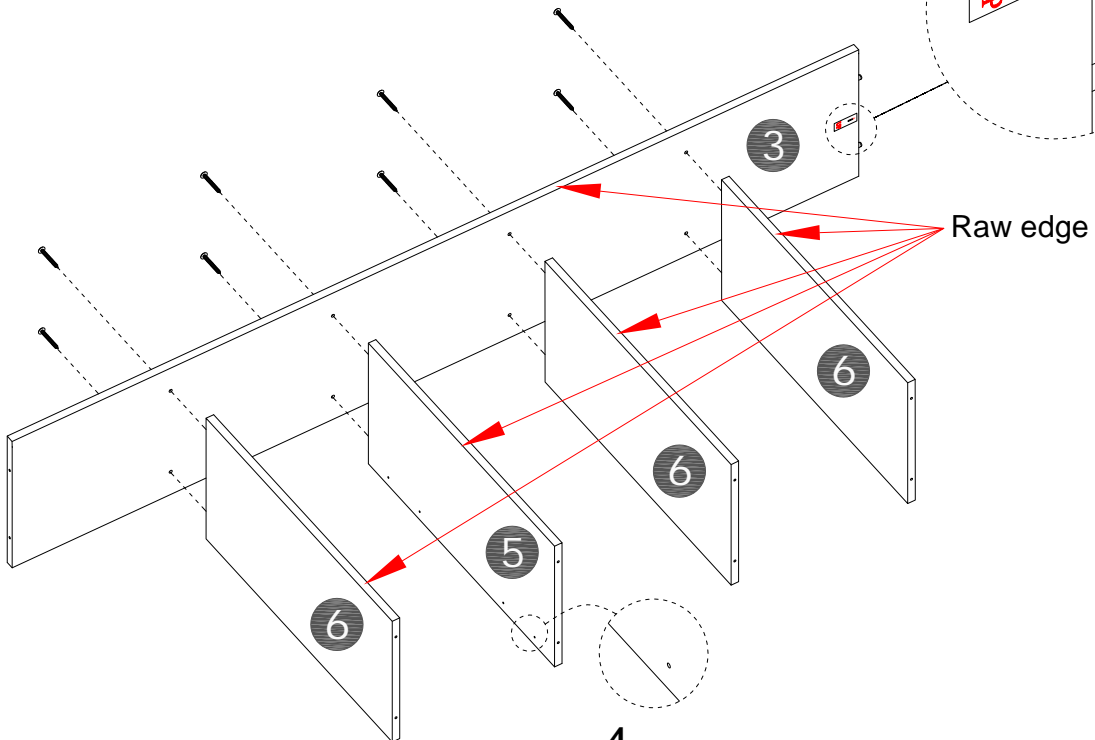
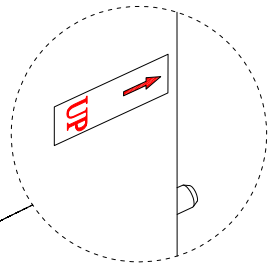
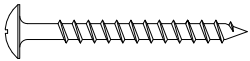

STEP 3

A x8pcs

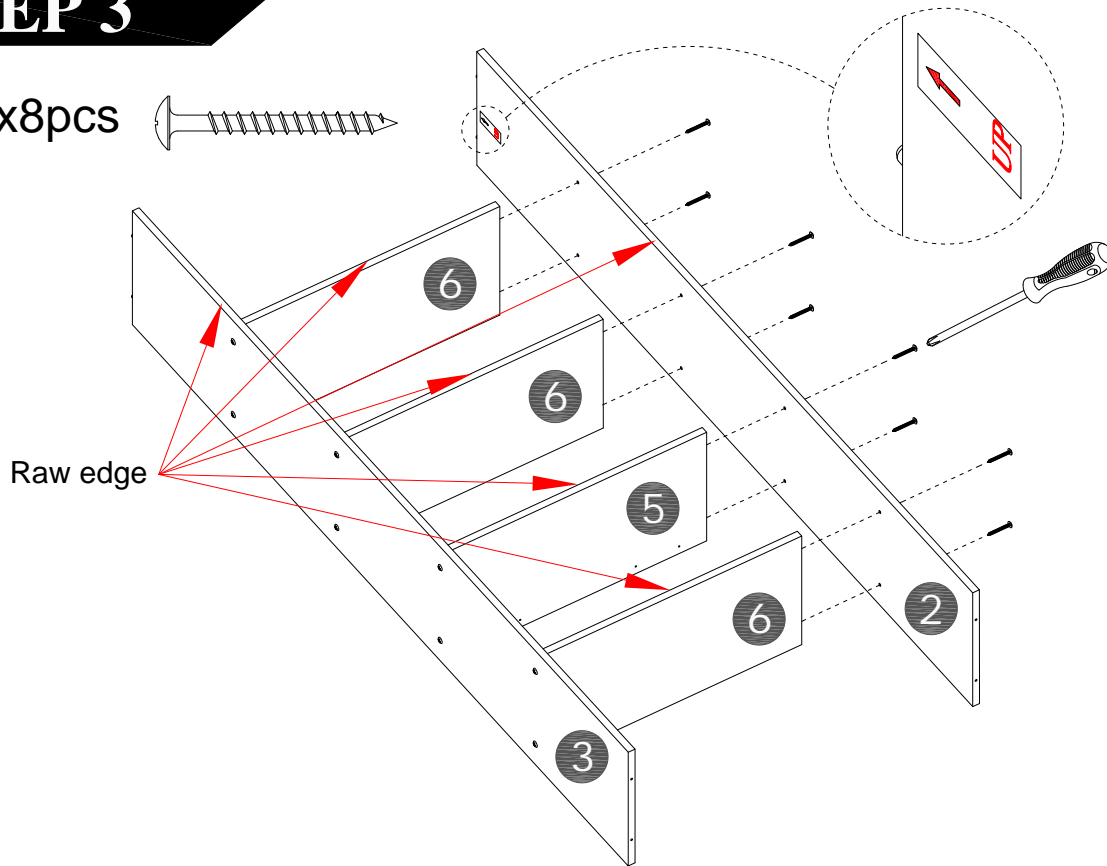

STEP 4

A x4pcs

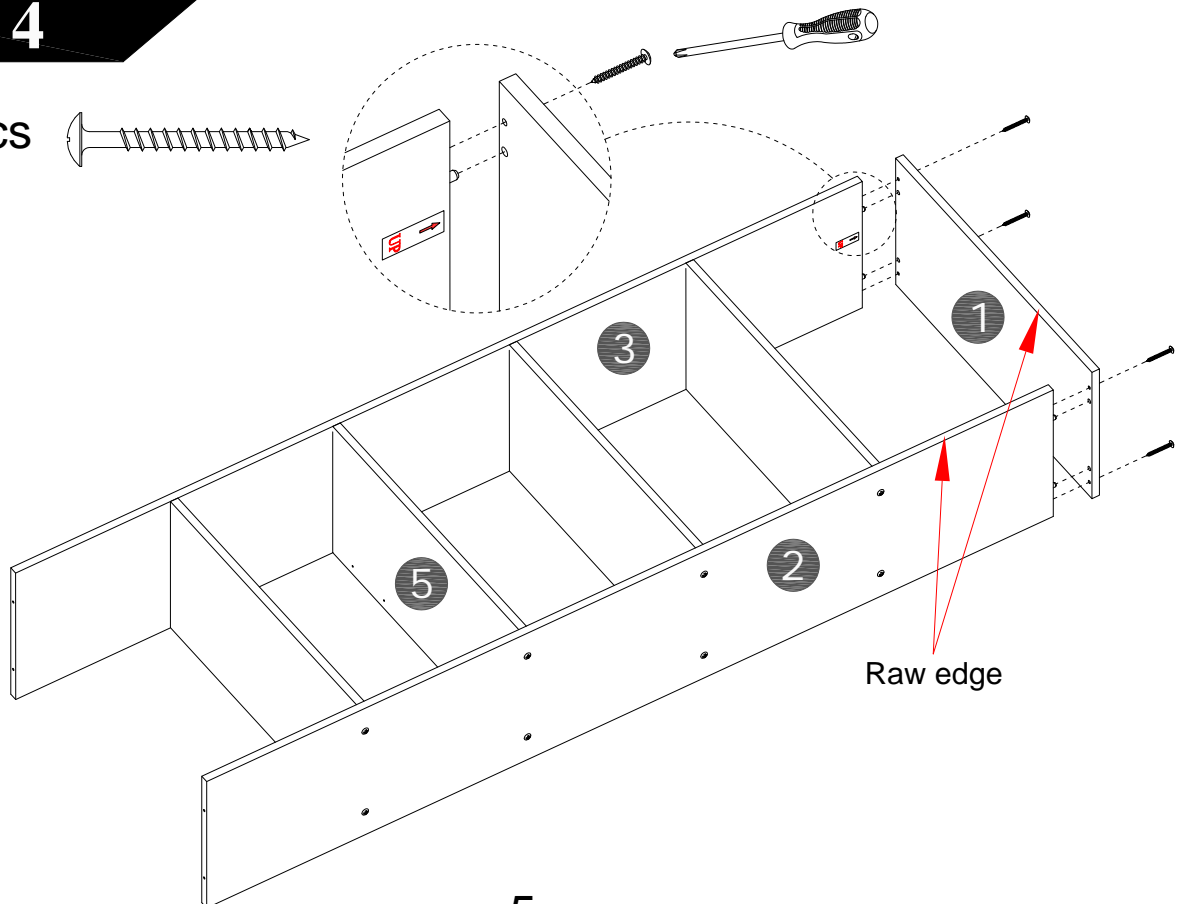

STEP 7

D x36pcs 

An assistant is required.

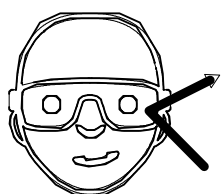

Safety glasses

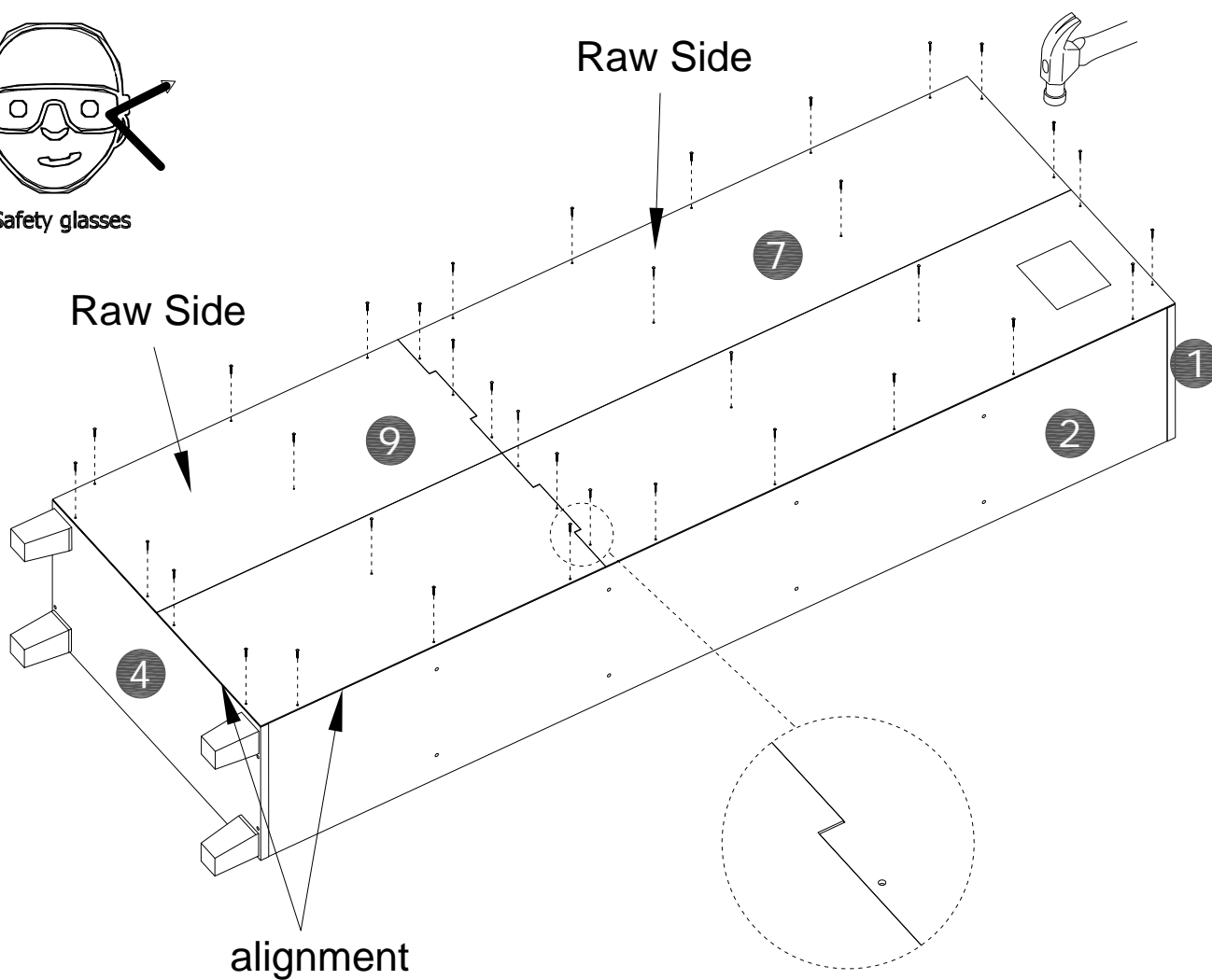

STEP 8

Peel off the adhesive sticker's protective paper and bond it onto the designated position before secure with nails.

F x2pcs

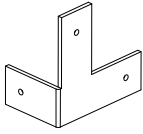

G x2pcs

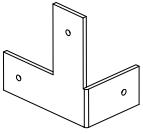

H x12pcs

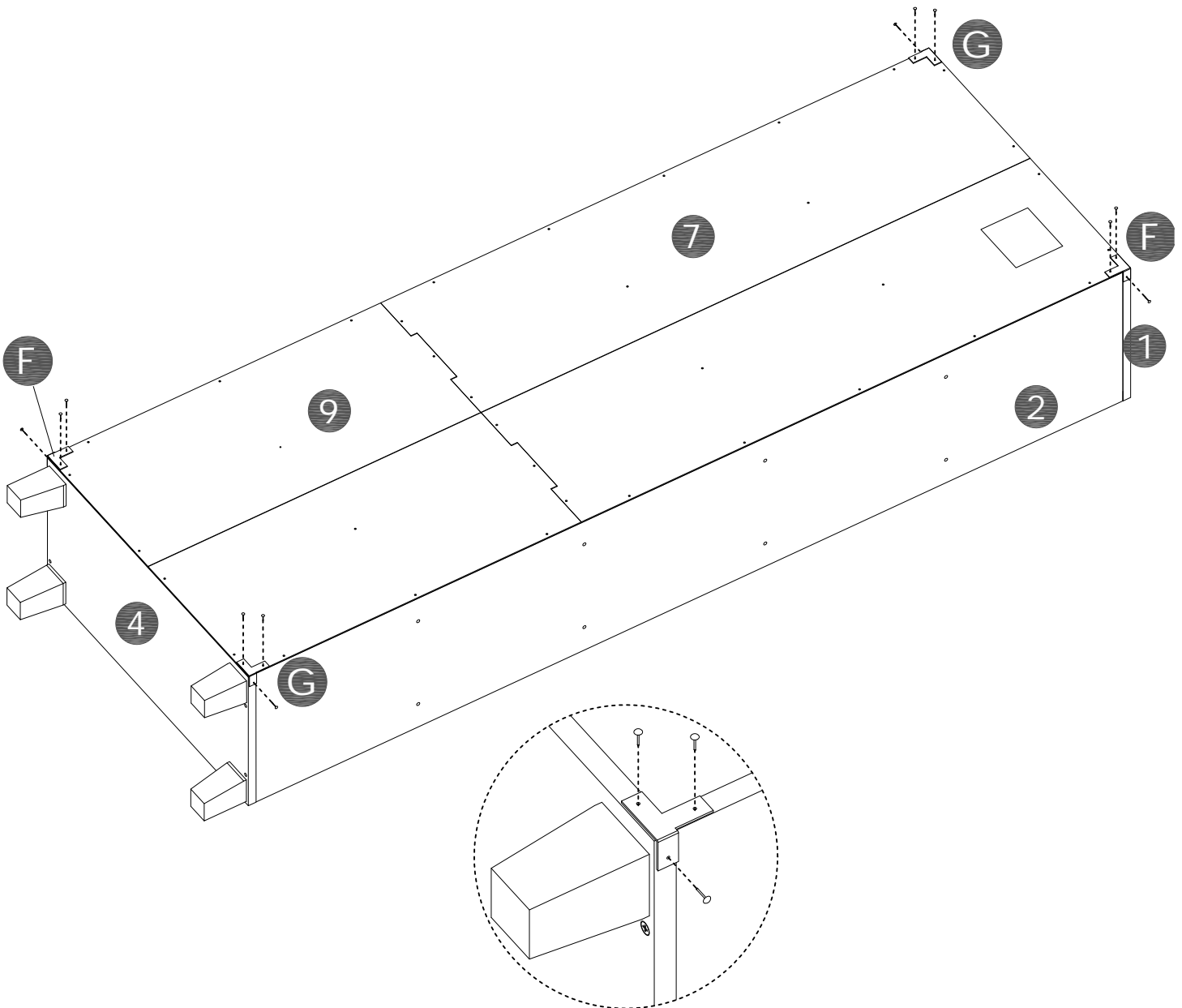
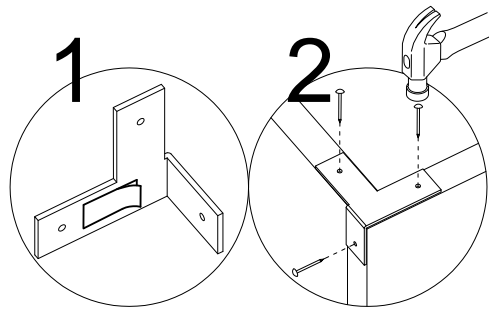

STEP 9

With assistant carefully flip the other side.

F x2pcs

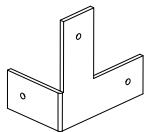

G x2pcs

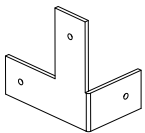

H x12pcs



Peel off the adhesive sticker's protective paper and bond it onto the designated position before secure with nails.

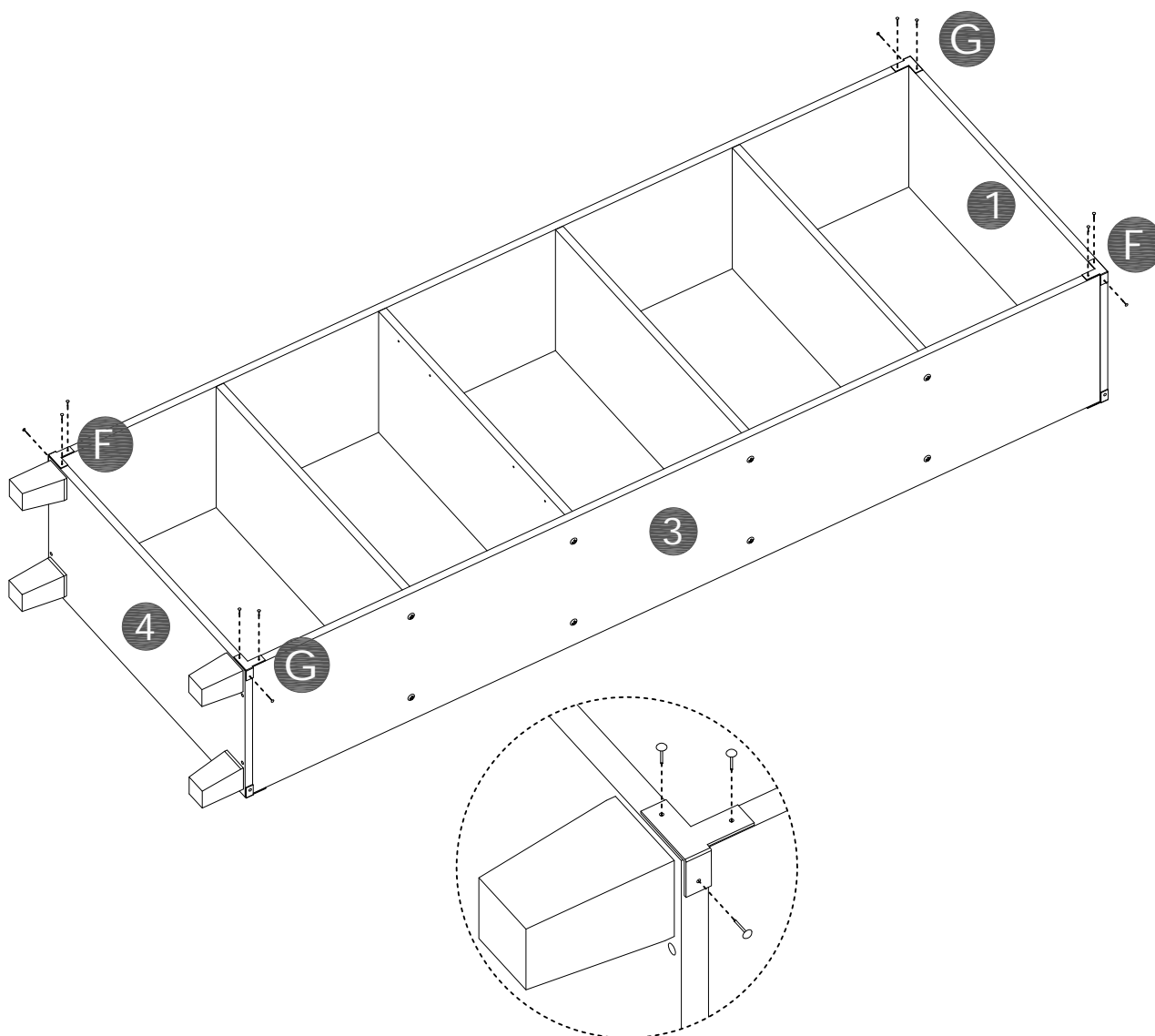
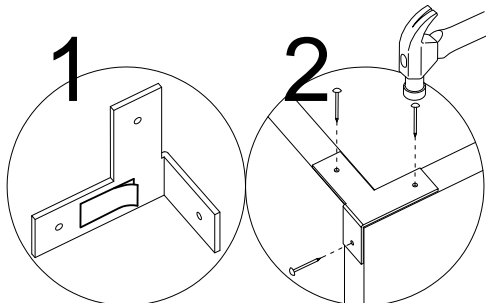

STEP 10

Peel off the adhesive sticker's protective paper and bond it onto the designated position before secure with nails.

E x8pcs 

H x24pcs 

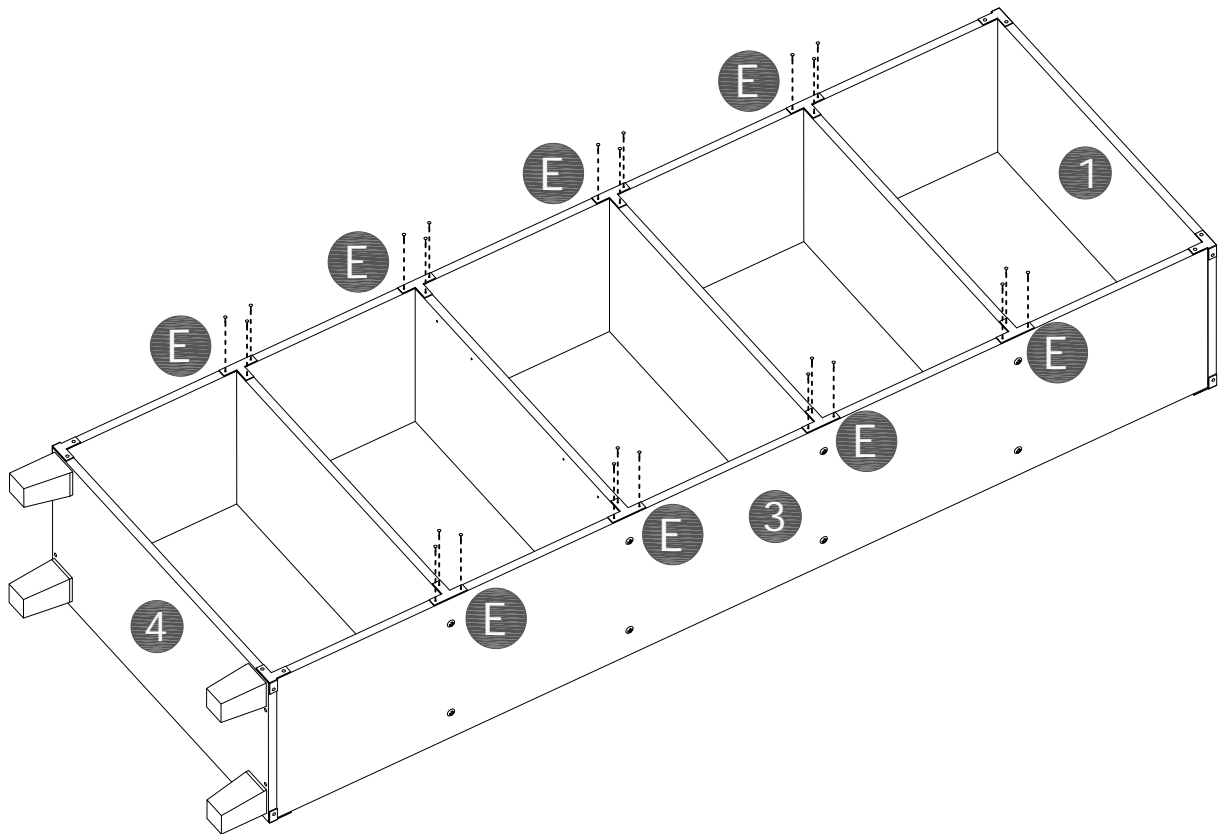
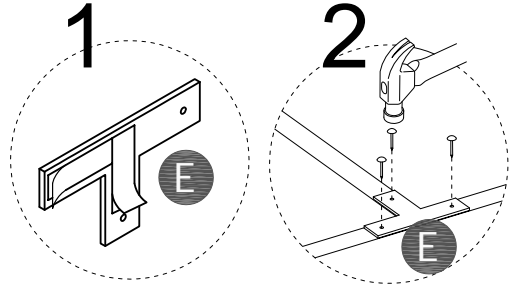

STEP 11

U₂ x1pcs

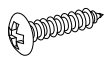

U₃ x1pcs

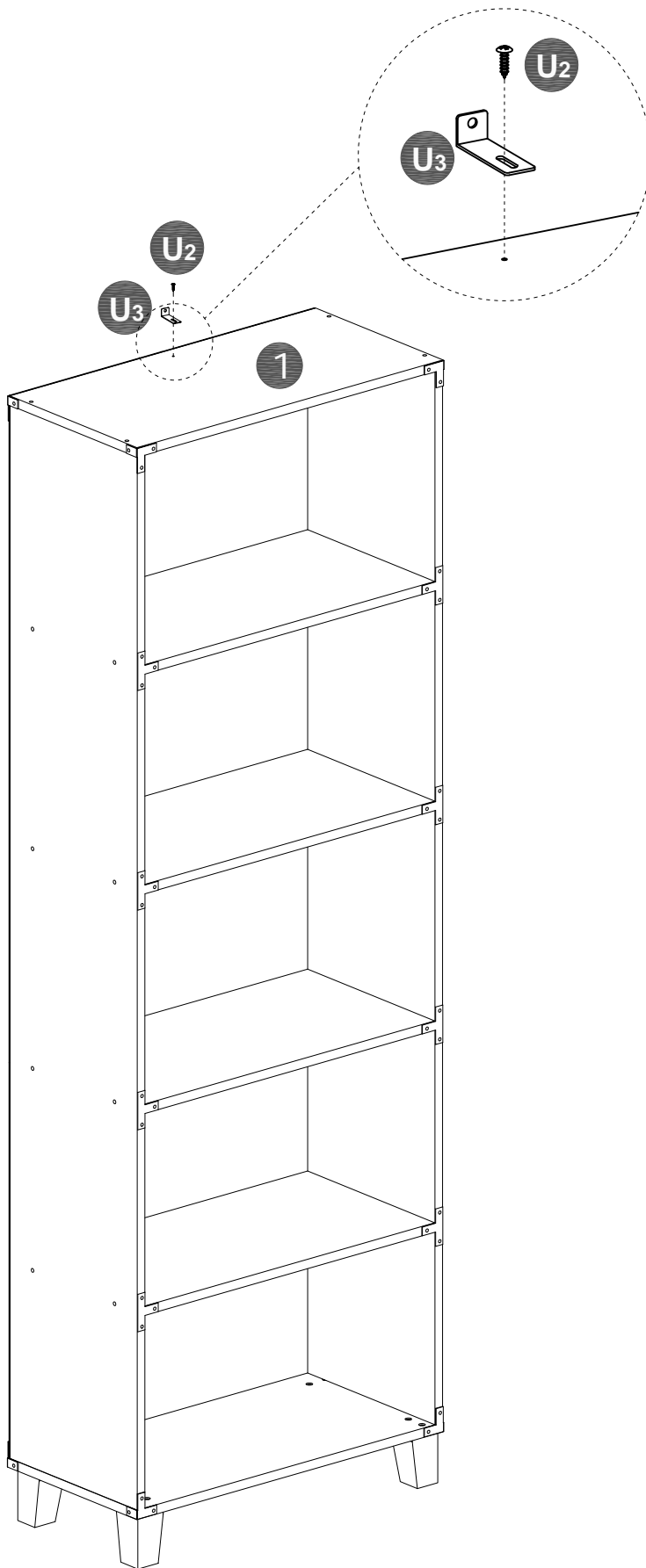

STEP 12

U₁ x 1pc 

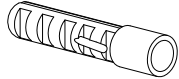
U₄ x 1pc 

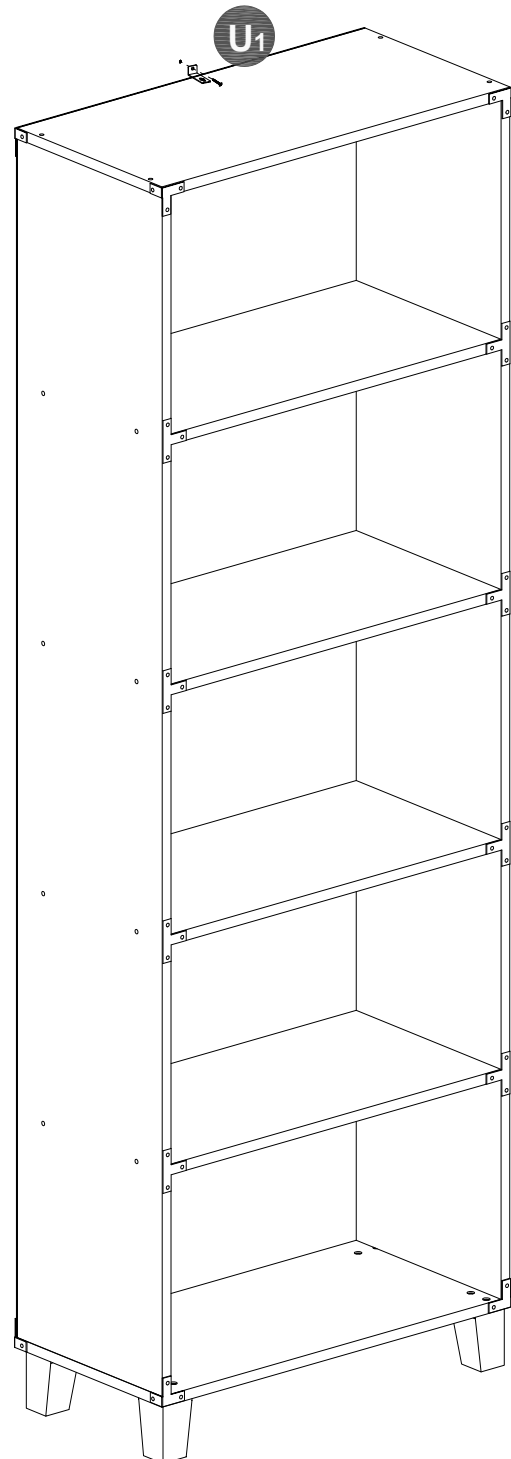
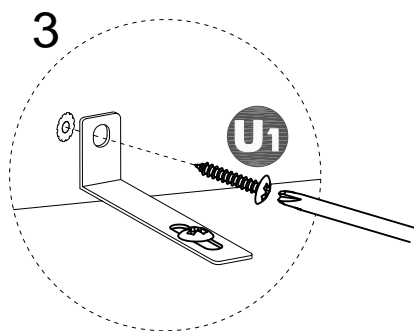
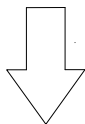
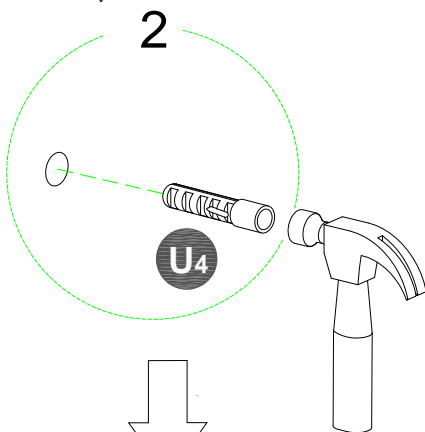
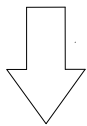
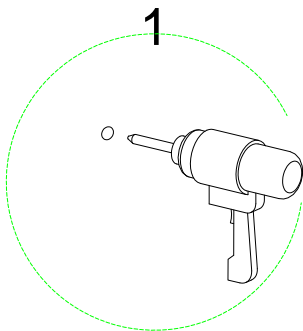

Maximum weight capacities

MAXIMUM WEIGHT: 0 LBS (0 KG)

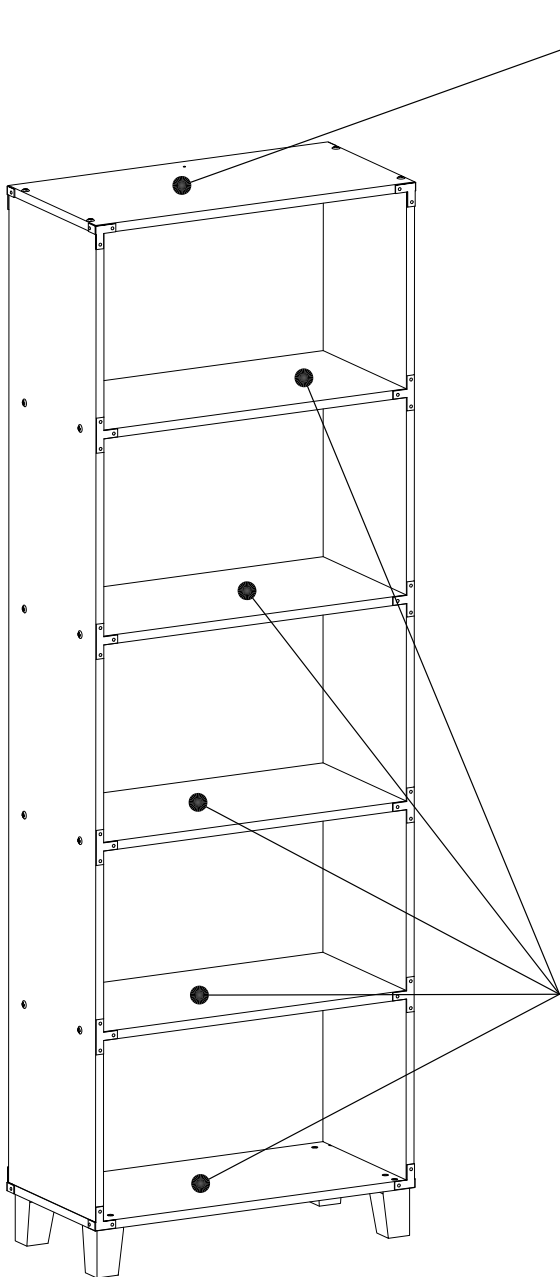

MAXIMUM WEIGHT: 26 LBS (12 KG)