

ASSEMBLY INSTRUCTIONS

ITEM#: FL1425

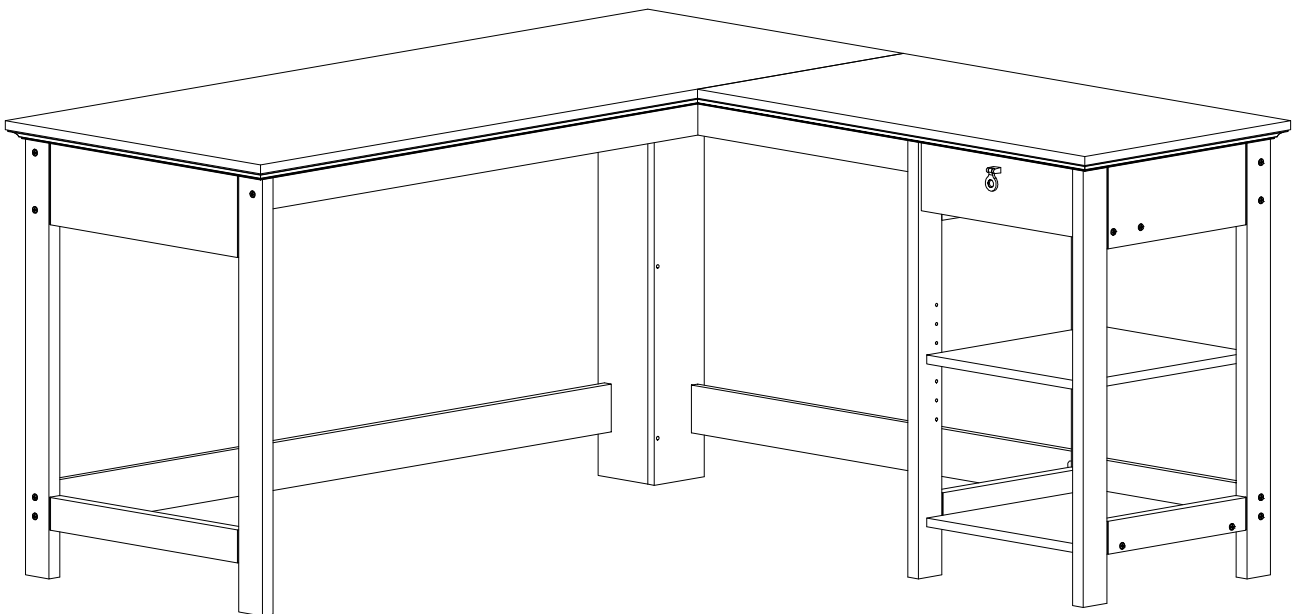





Important Safety Instructions:

- Please read all instructions before beginning assembly
- Please make sure receive all the parcels to start the assembly
- For your safety and convenience, assembly by two people is recommended
- Use the parts and hardware lists to identify and separate each of the components included
- Save all packing materials until assembly is completed to avoid the accidental discarding of smaller parts or hardware

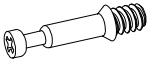

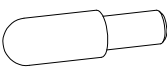
THANK YOU FOR PURCHASING

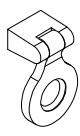
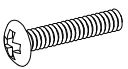
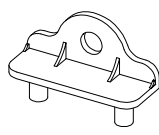
HARDWARE LIST

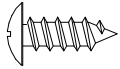
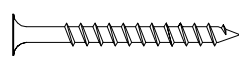
Name	Part	Qty.	Spare
A		18	1
B		18	1
C		29	1
D		4	
E		4	1
F		1	
G		1	1
H		2	
I	 2-3/8" Screw	18	1
J	 1/2" Screw	4	
K	 2" Screw	16	1

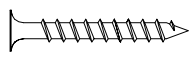
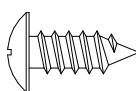
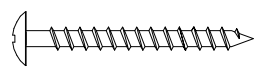
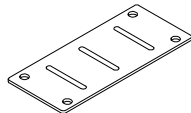
Name	Part	Qty.	Spare
L	 1-1/2" Screw	4	
M	 9/16" Screw	6	
O	 2" Screw	7	
P		1	

STEP 1

C x12pcs 

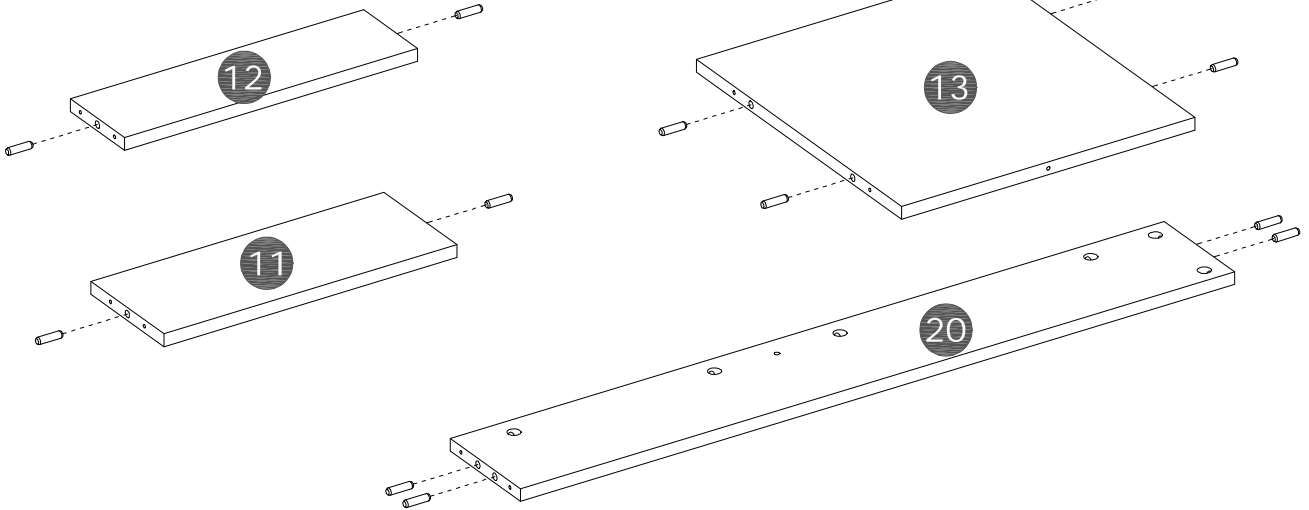
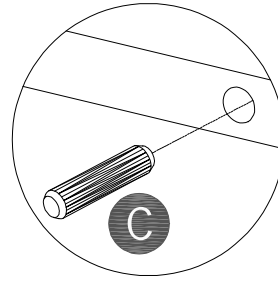

STEP 2

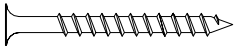
K x1pcs 

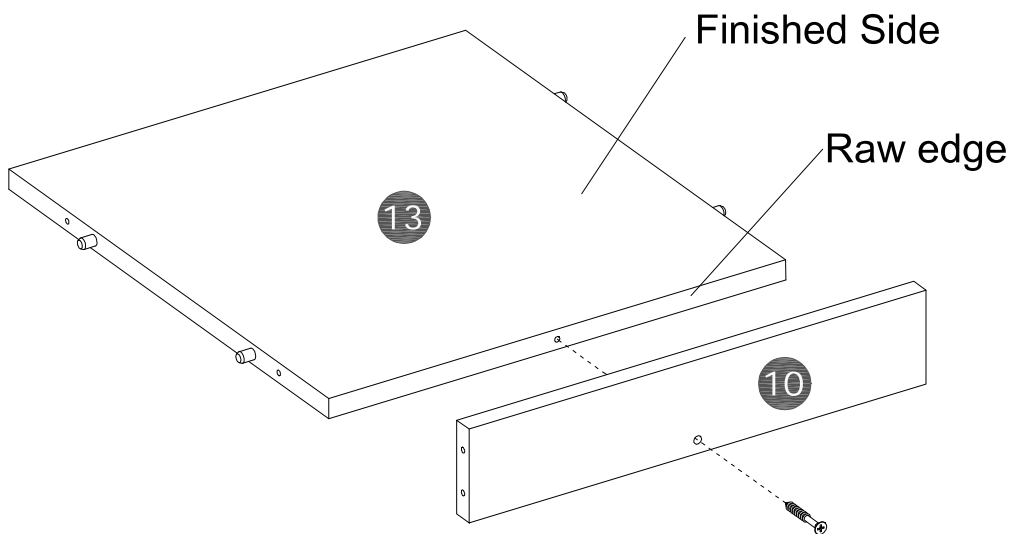

STEP 3

I x8pcs
2-3/8" Screw

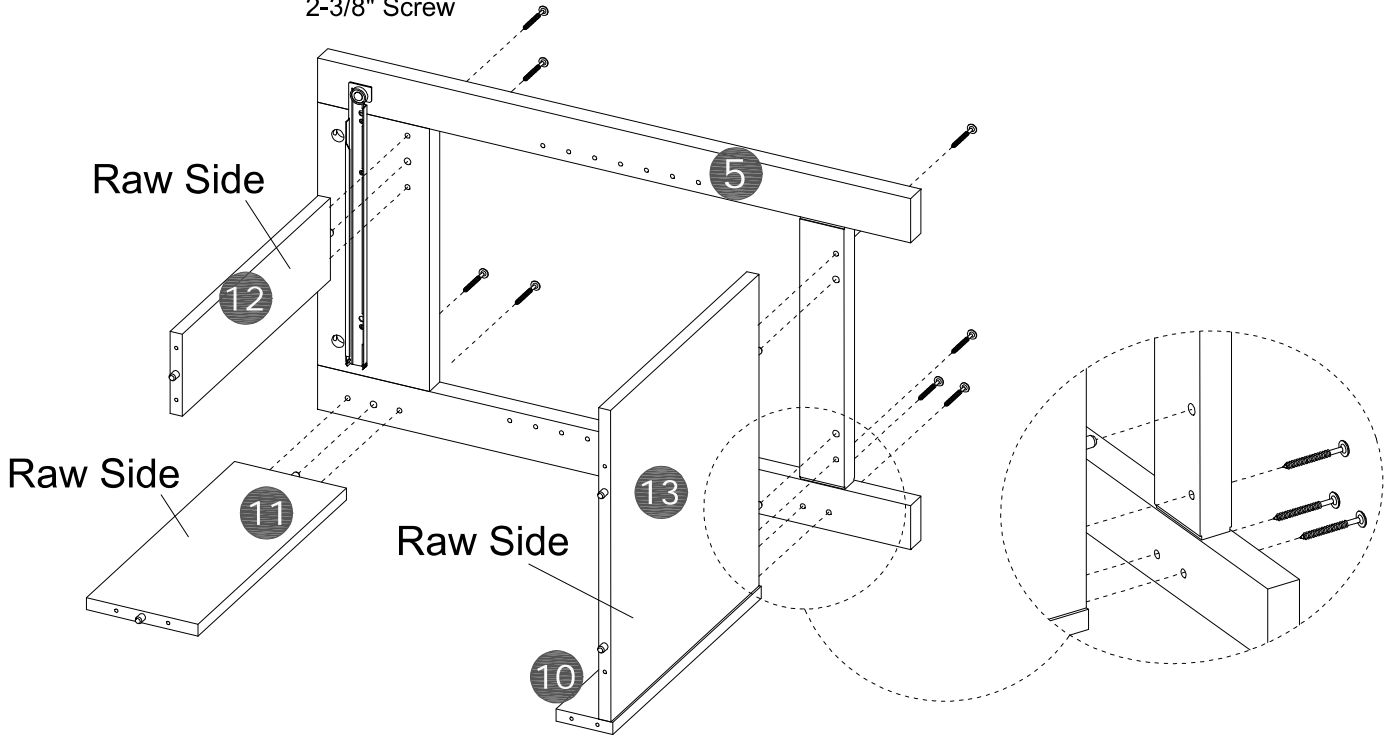

STEP 4

A x4pcs

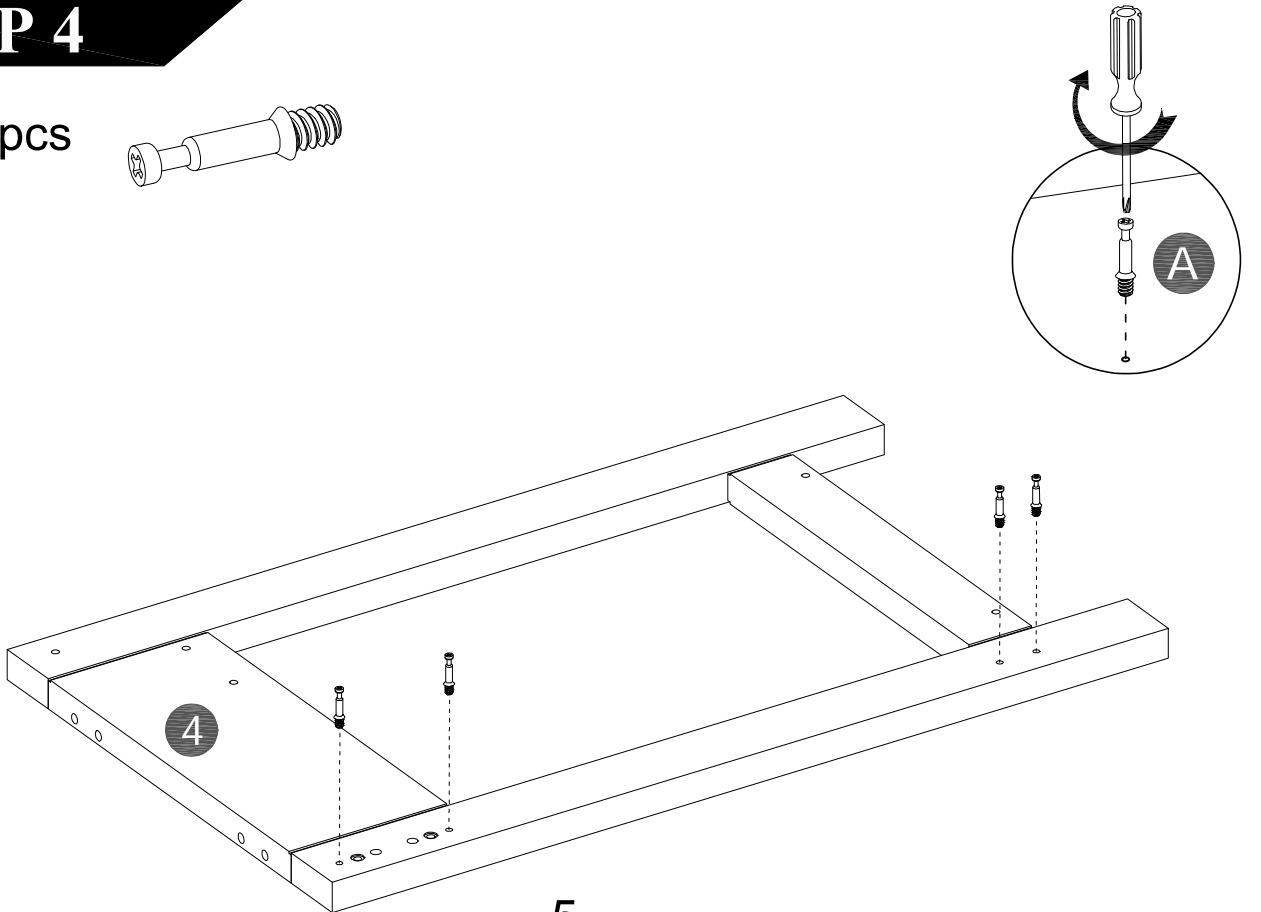

STEP 5

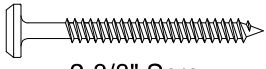
I x4pcs  2-3/8" Screw

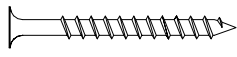
K x2pcs 

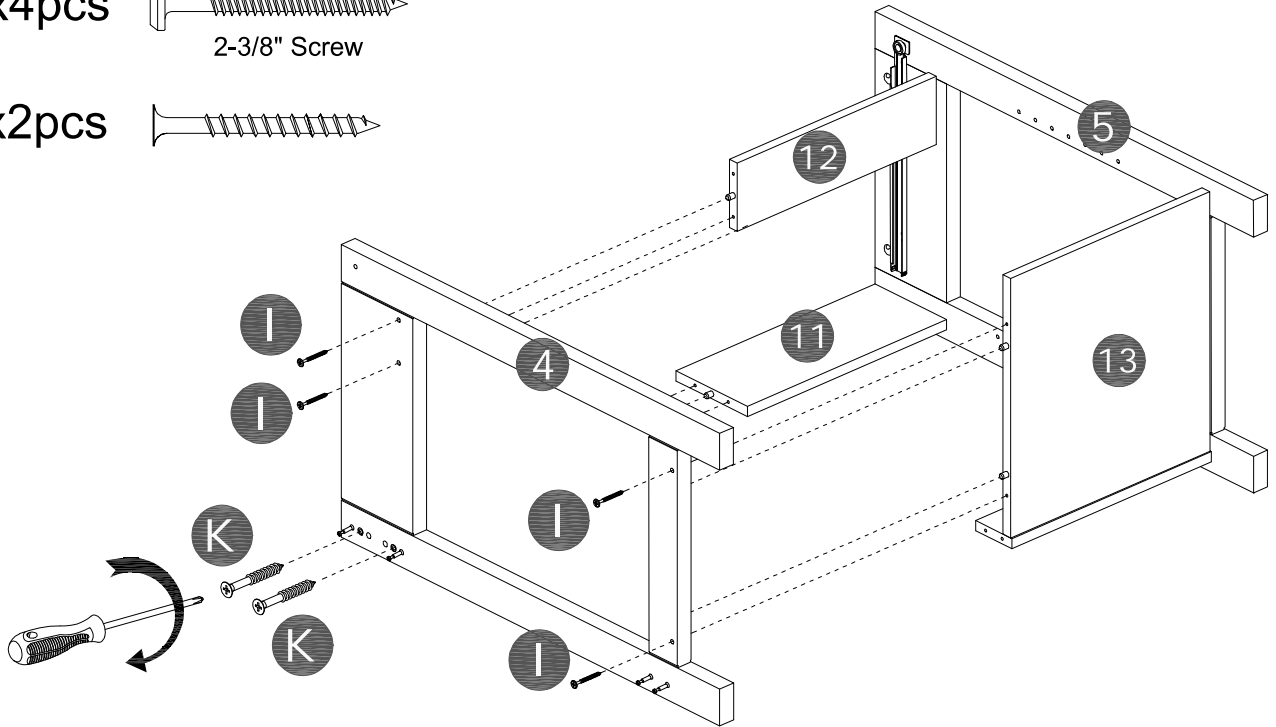

STEP 6

B x4pcs 

E x4pcs 

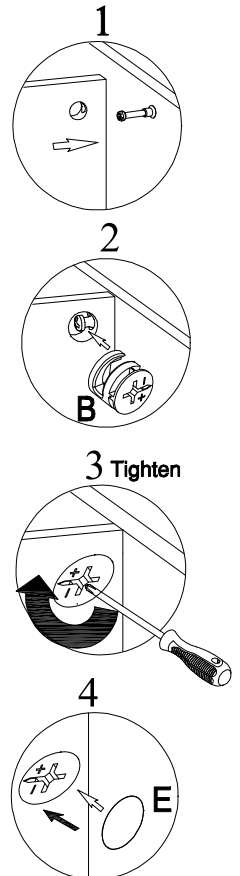
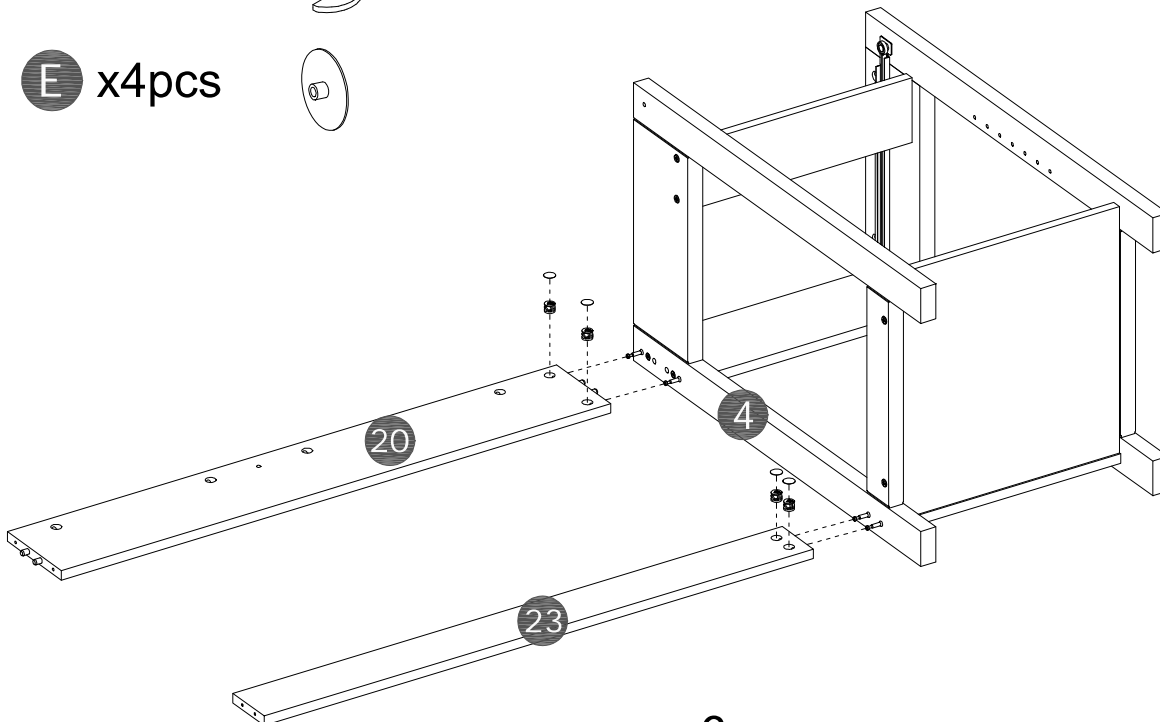

STEP 7

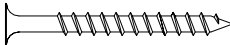
K x4pcs 

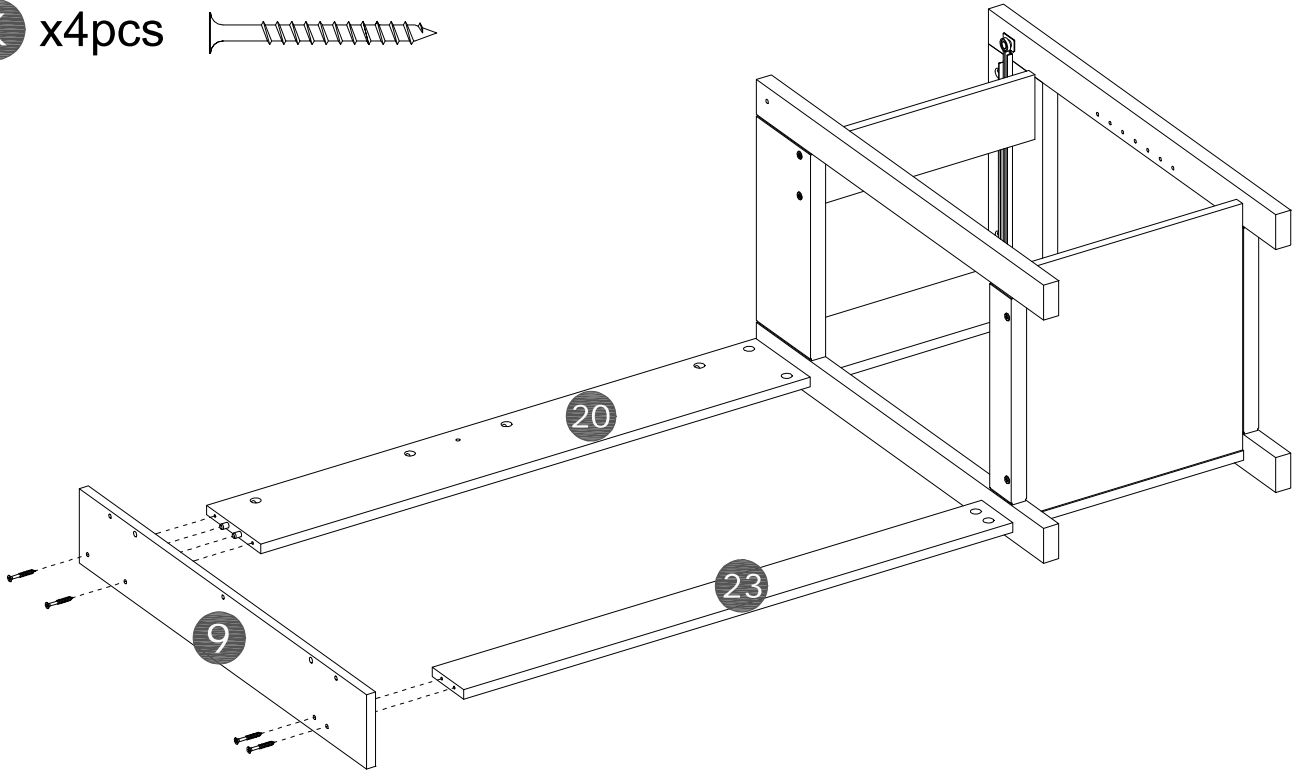

STEP 8

C x6pcs 

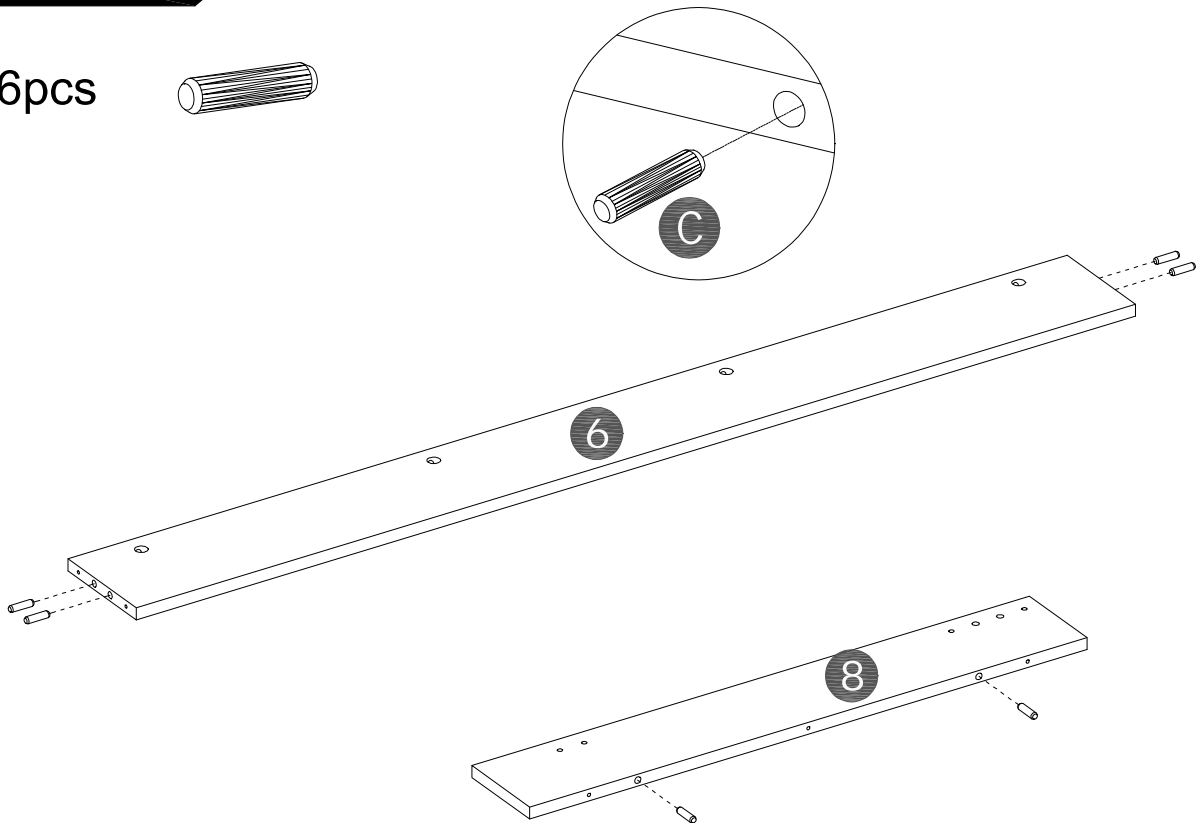

STEP 9

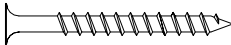
K x4pcs 

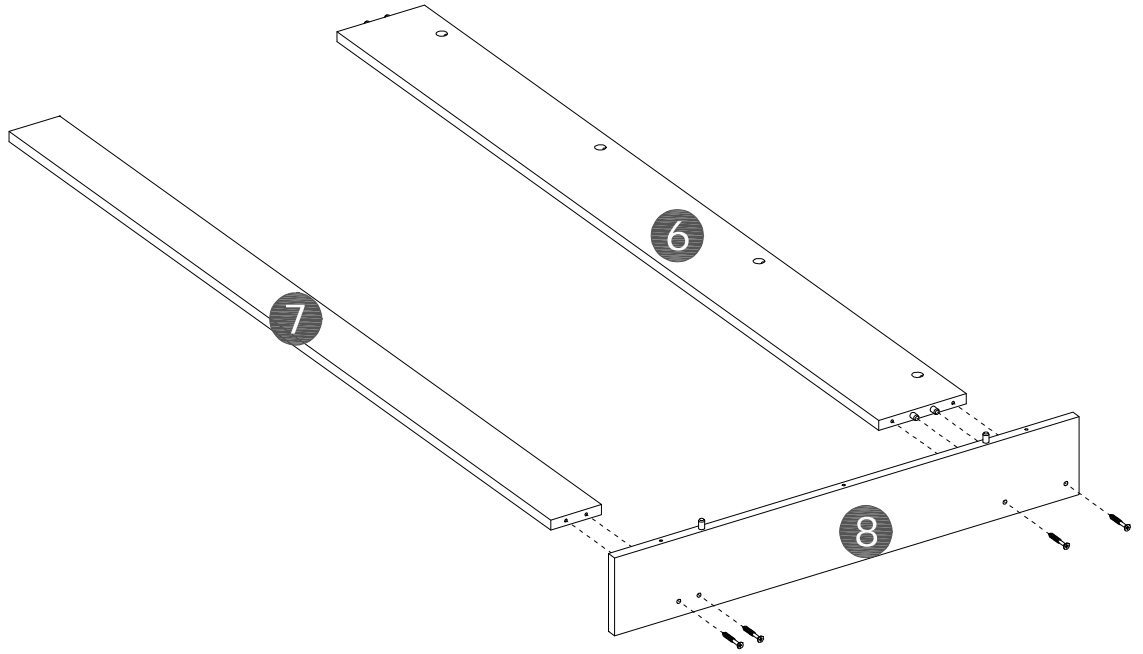

STEP 10

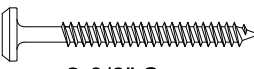
I x4pcs 
2-3/8" Screw

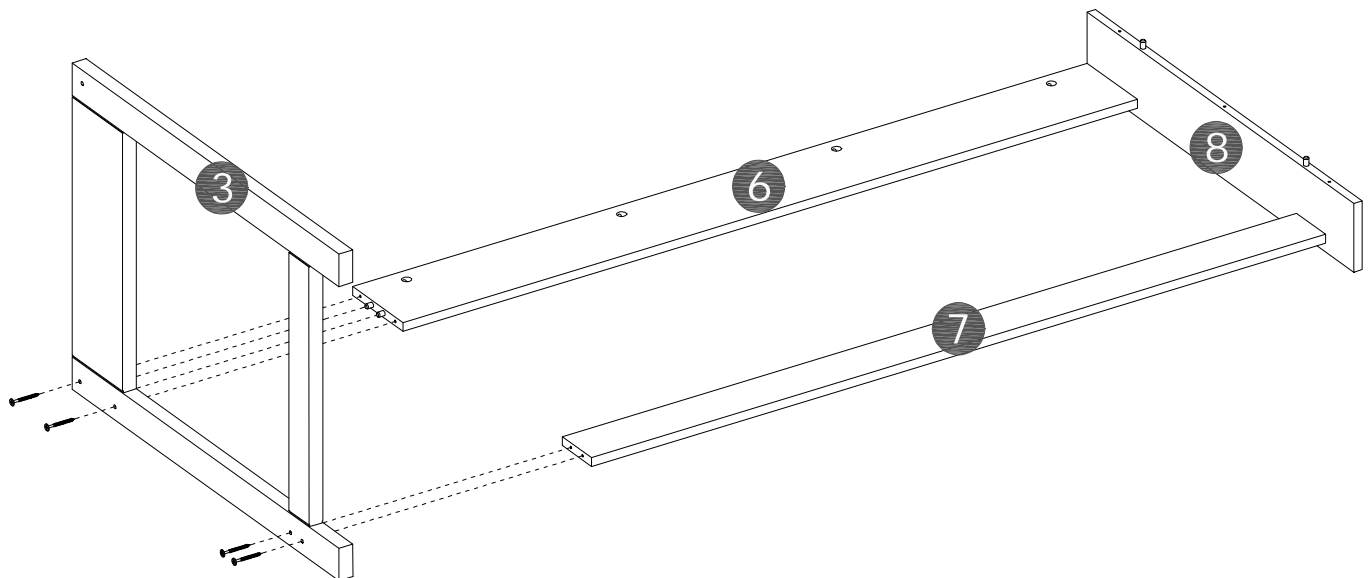

STEP 11

With assistant carefully stand unit up.
An assistant is required.

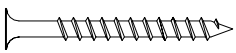
K x3pcs 

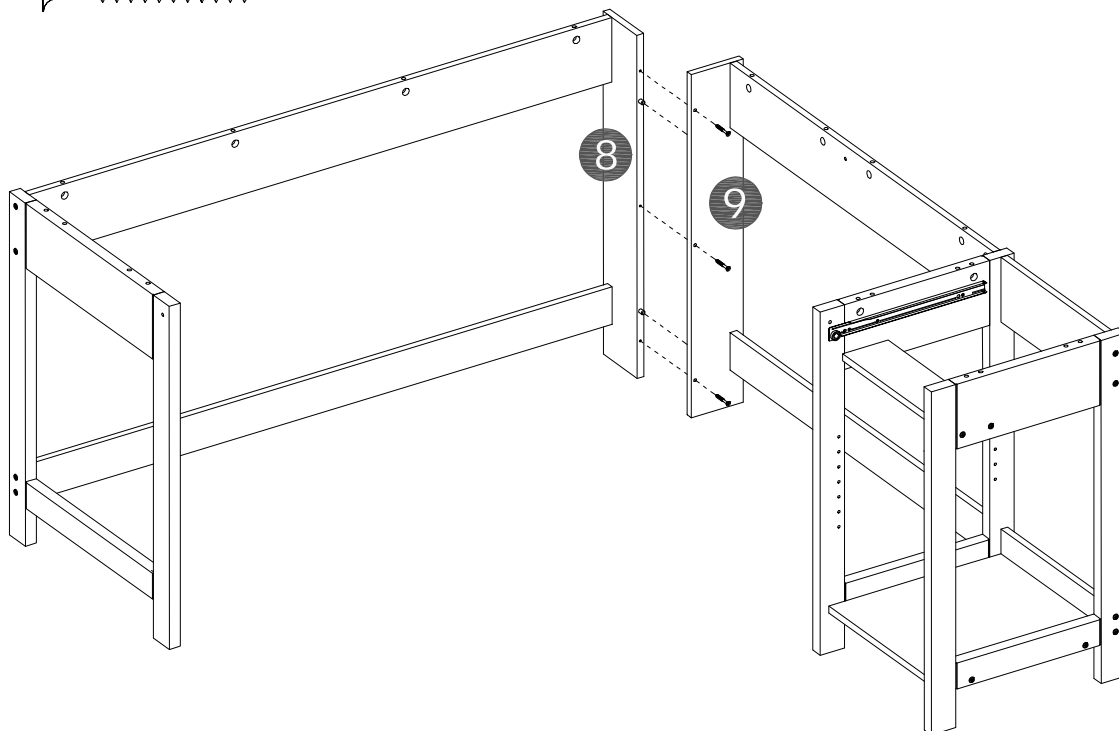

STEP 12

This hole is here.

L x2pcs 
2-3/8" Screw

An assistant is required.

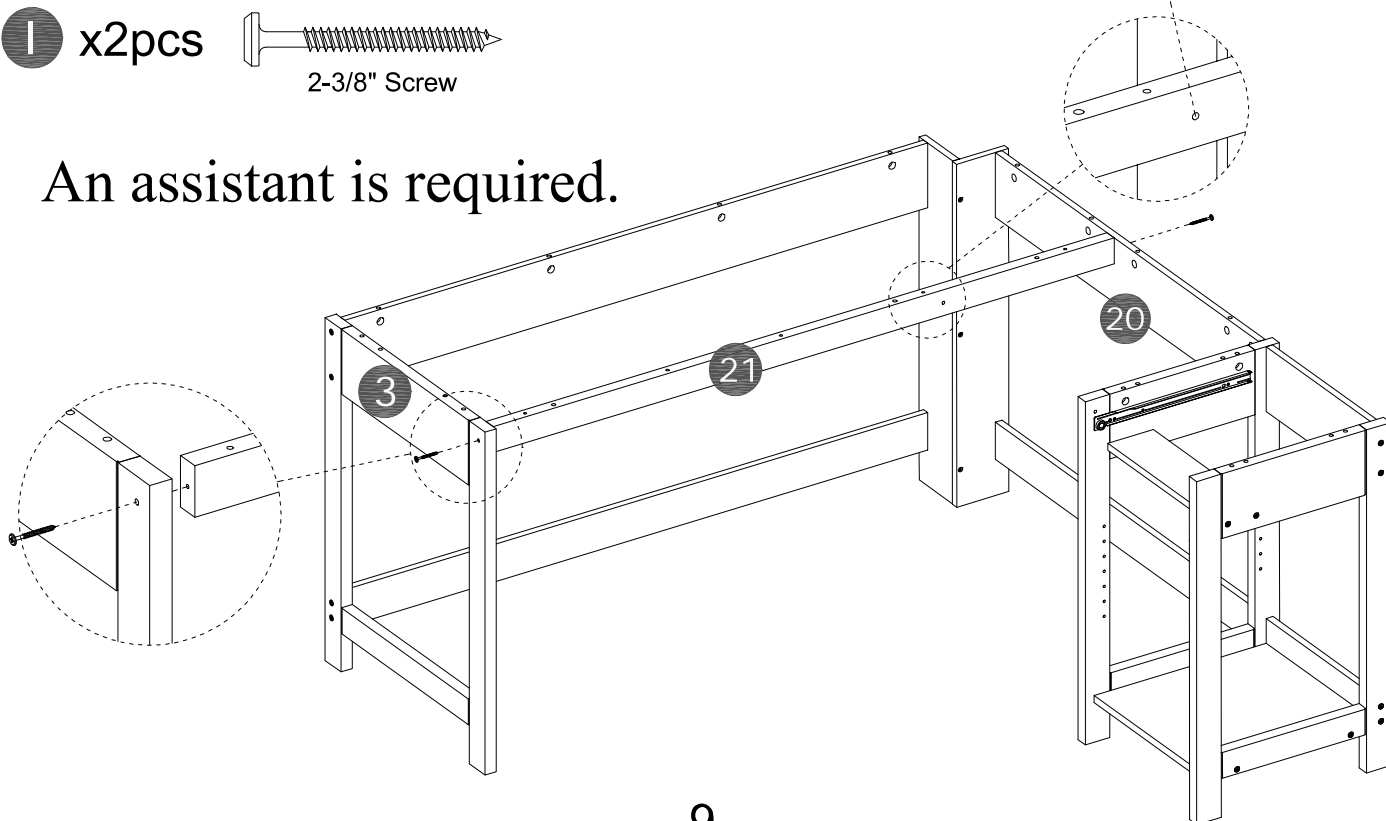

STEP 13

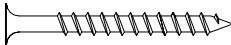
K x2pcs 

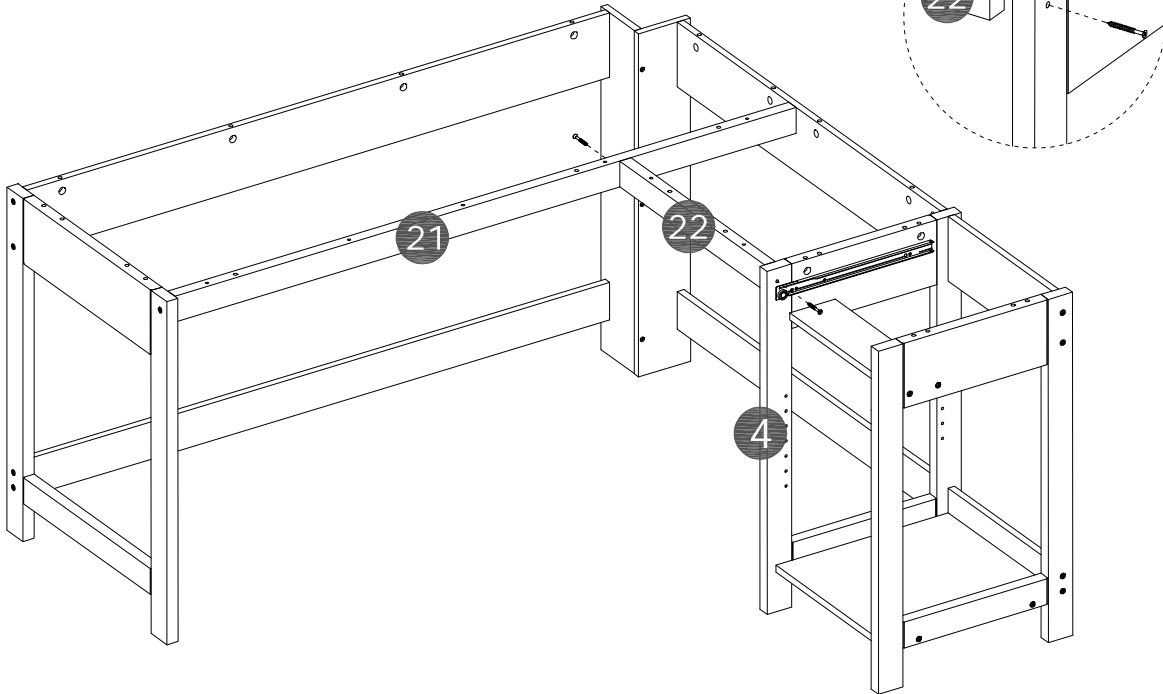

STEP 14

C x11pcs 

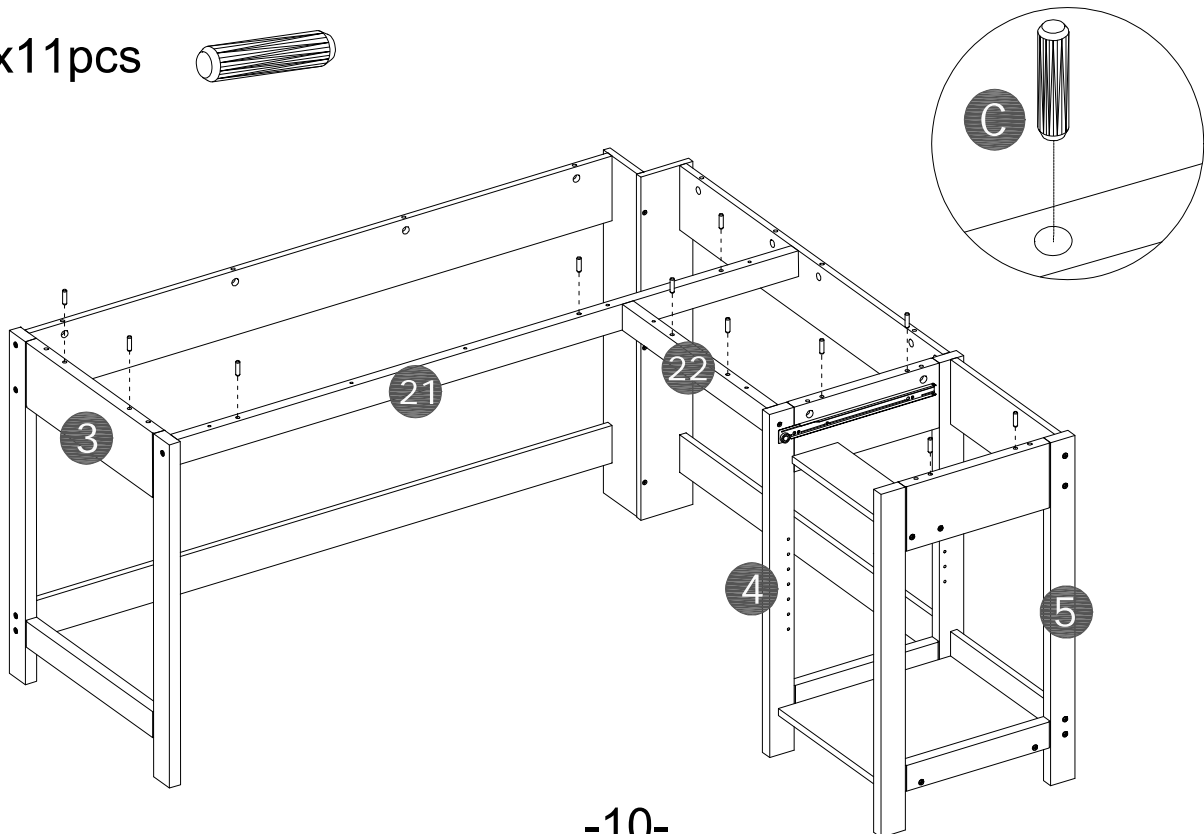

STEP 15

A x6pcs

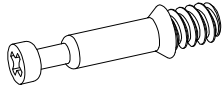

M x2pcs

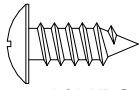

9/16" Screw

P x1pcs

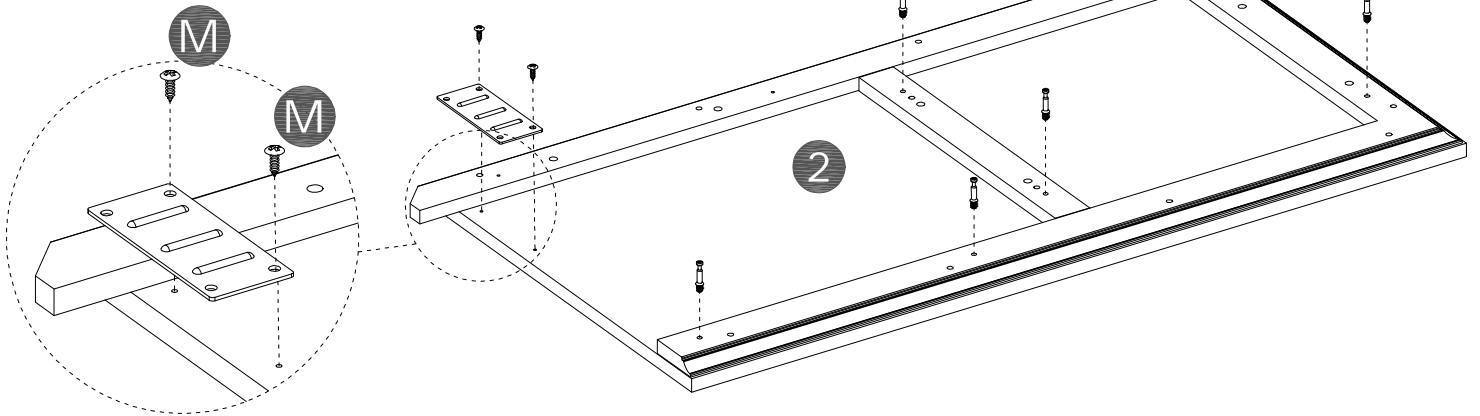
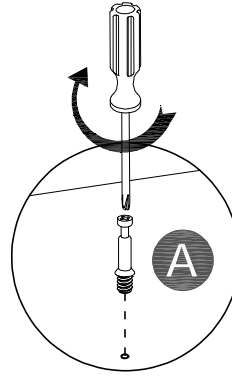
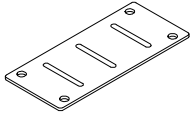

STEP 16

B x6pcs

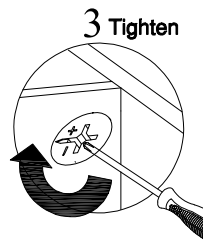
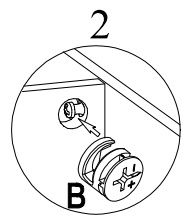
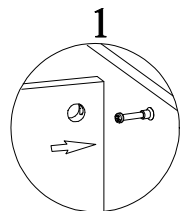
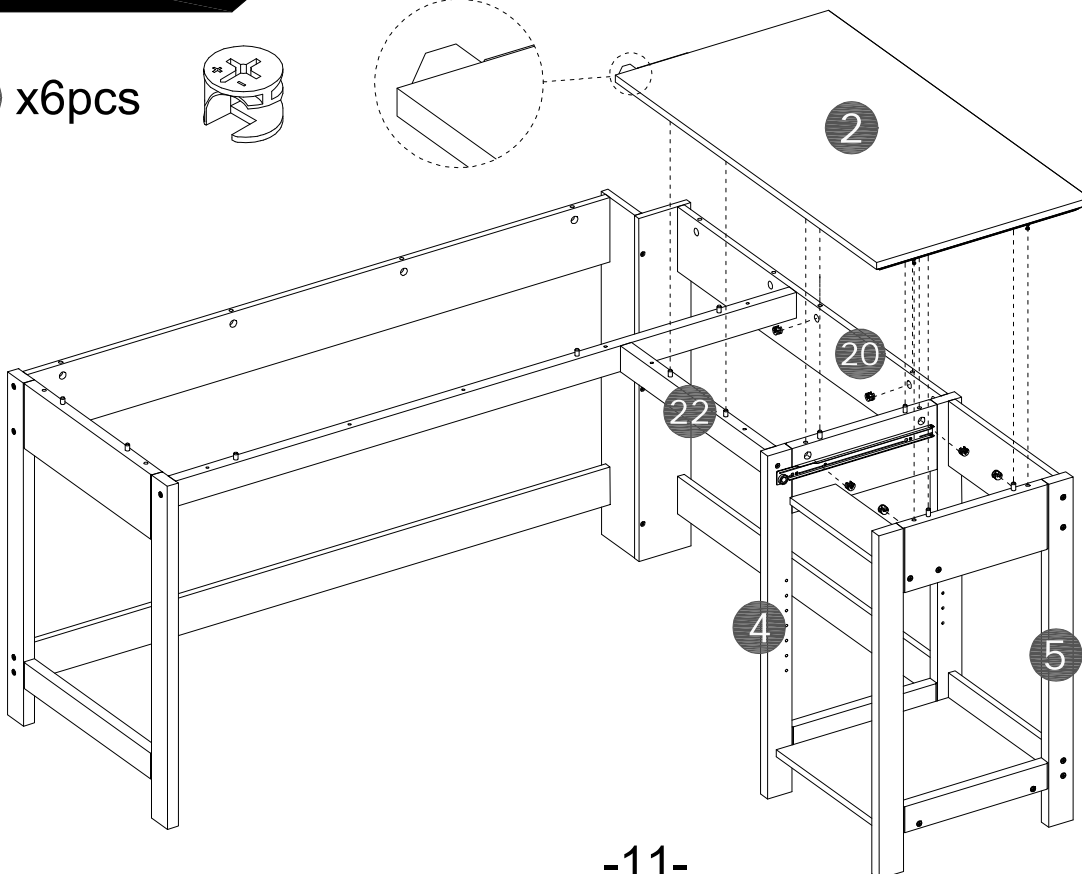
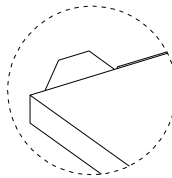

STEP 17

A x8pcs

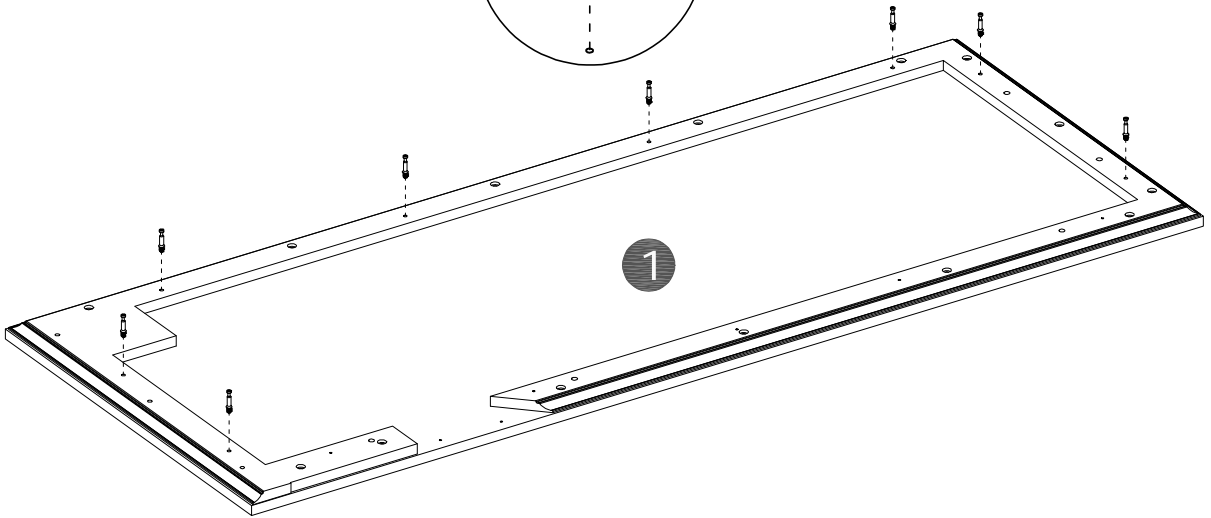
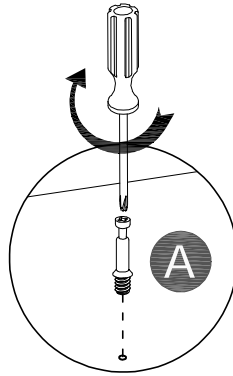
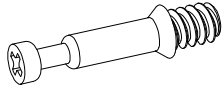

STEP 18

An assistant is required.

B x8pcs

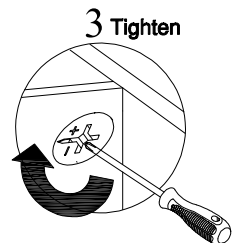
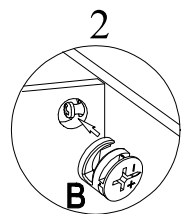
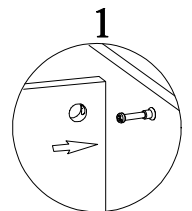
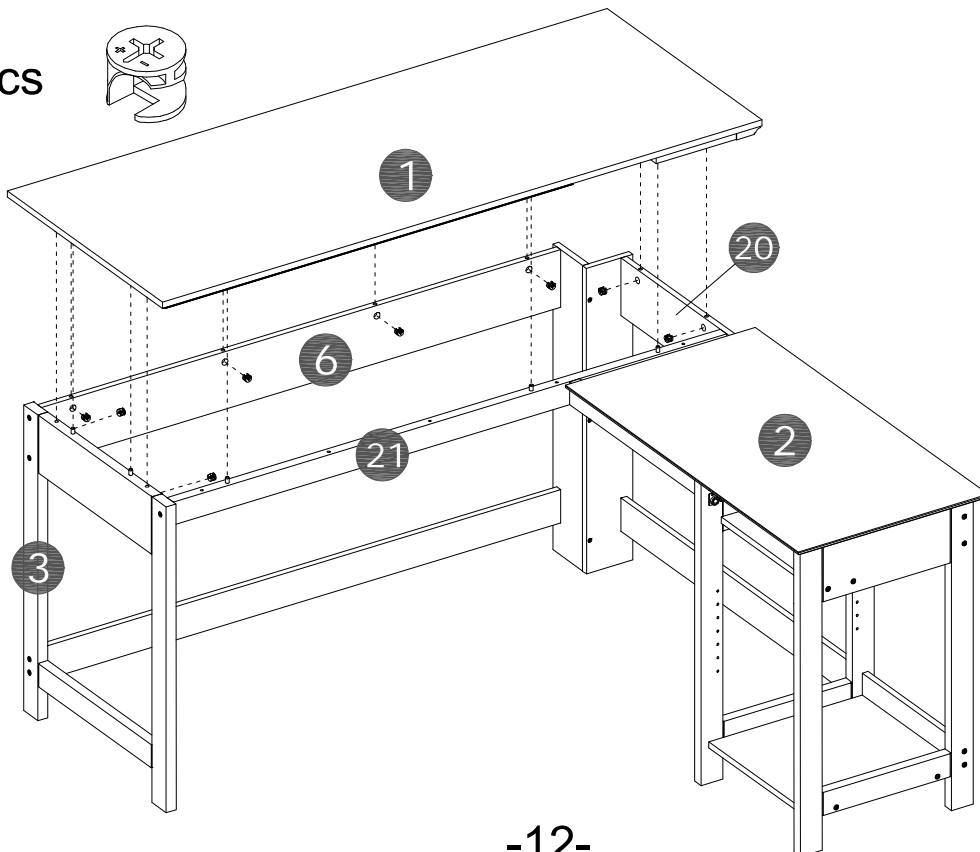

STEP 19

○ x7pcs

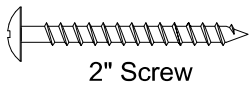

M x2pcs

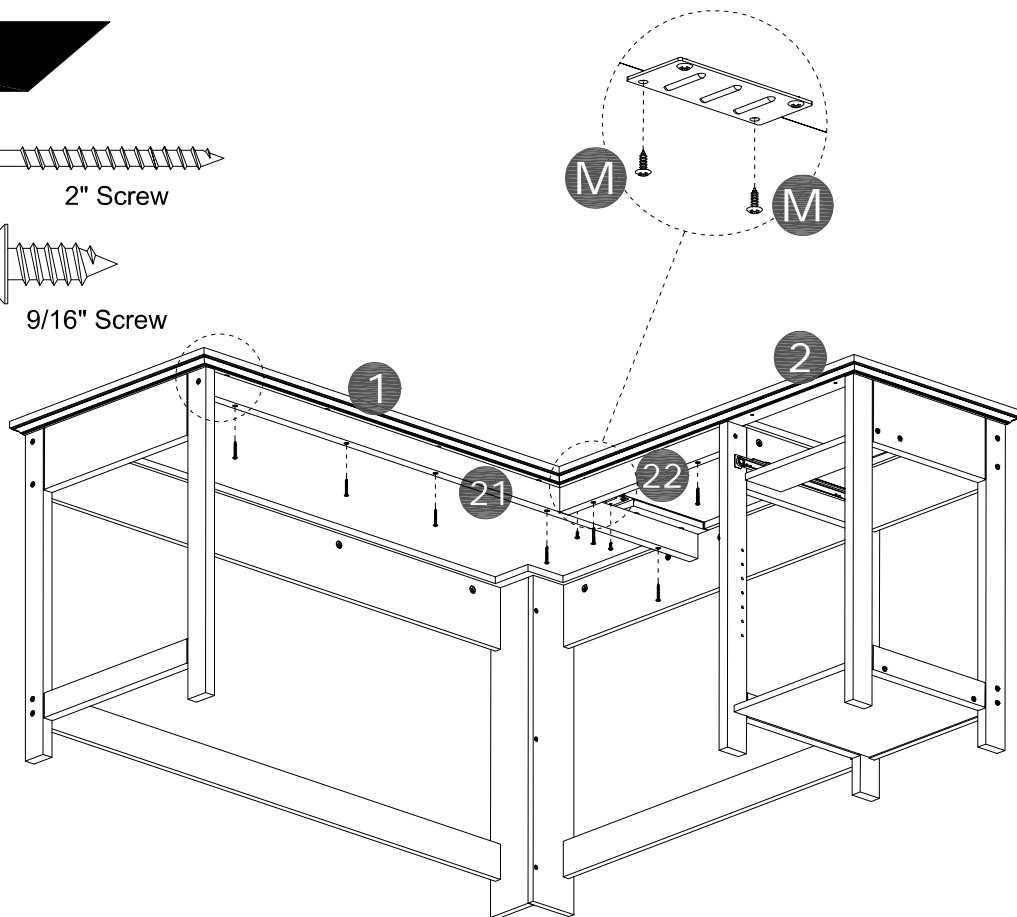
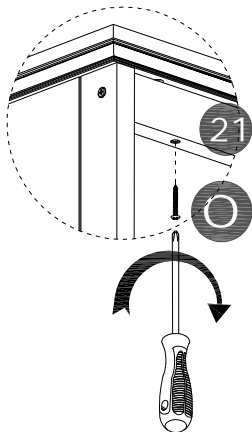
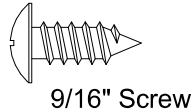

STEP 20

Do not use power screw driver,
use manual screw driver.

H x2pcs

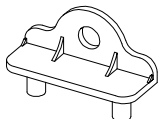

M x2pcs

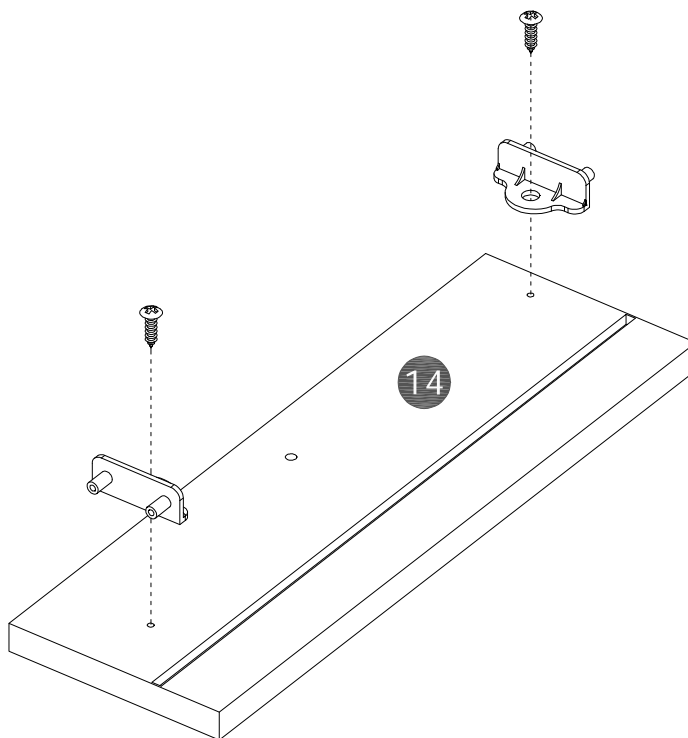
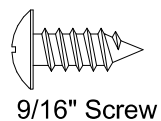

STEP 21

Do not use power screw driver,
use manual screw driver.

J x4pcs 

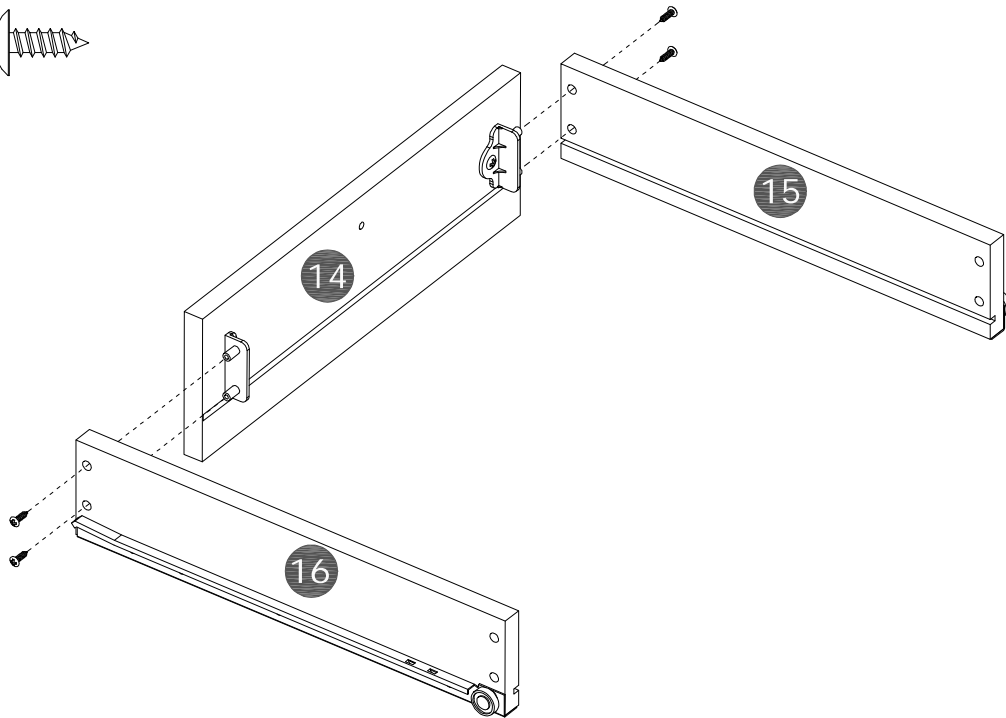

STEP 22

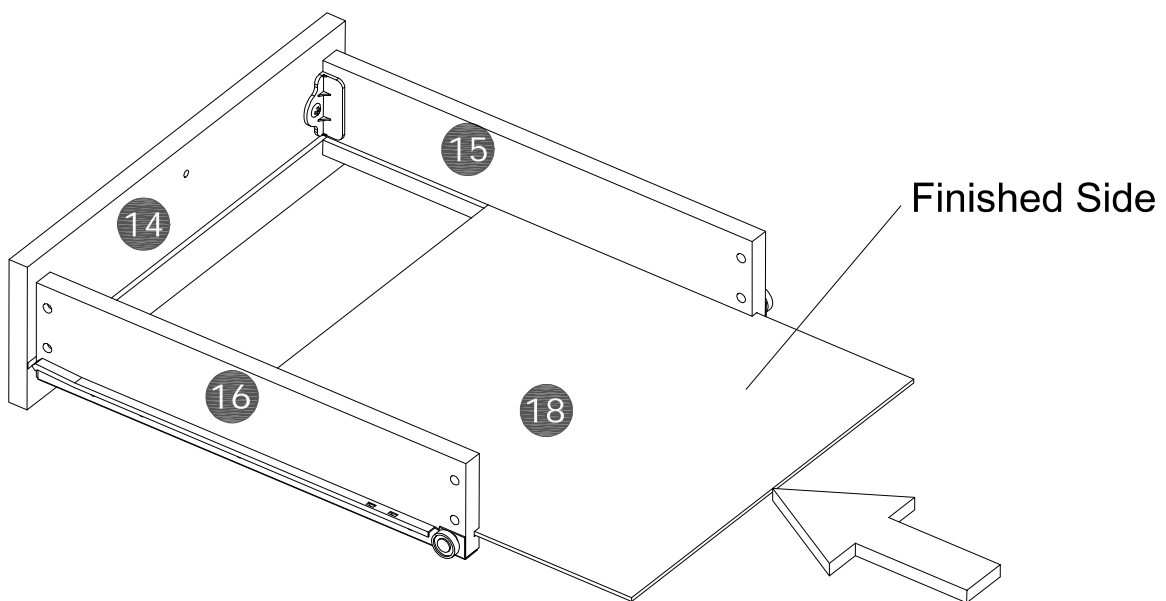

STEP 23

L x4pcs 

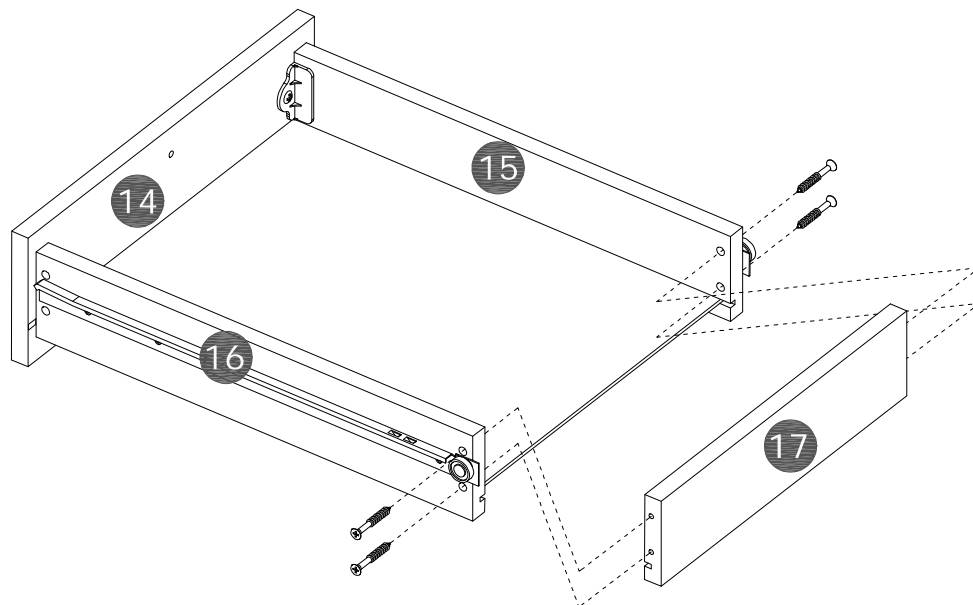

STEP 24

F x1pc



G x1pc

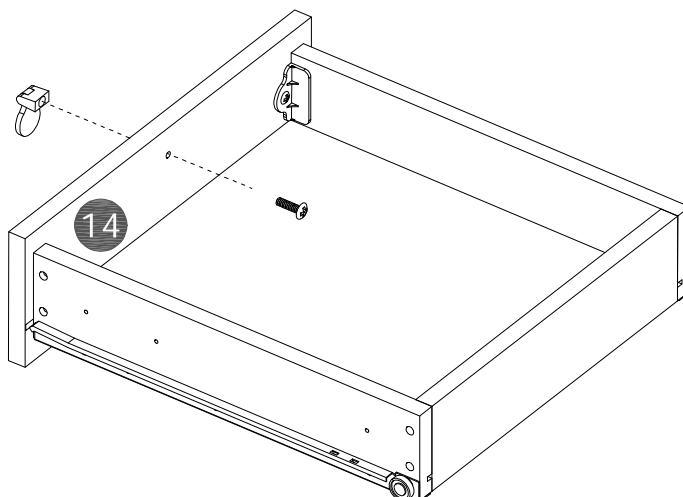
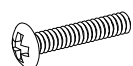

STEP 25

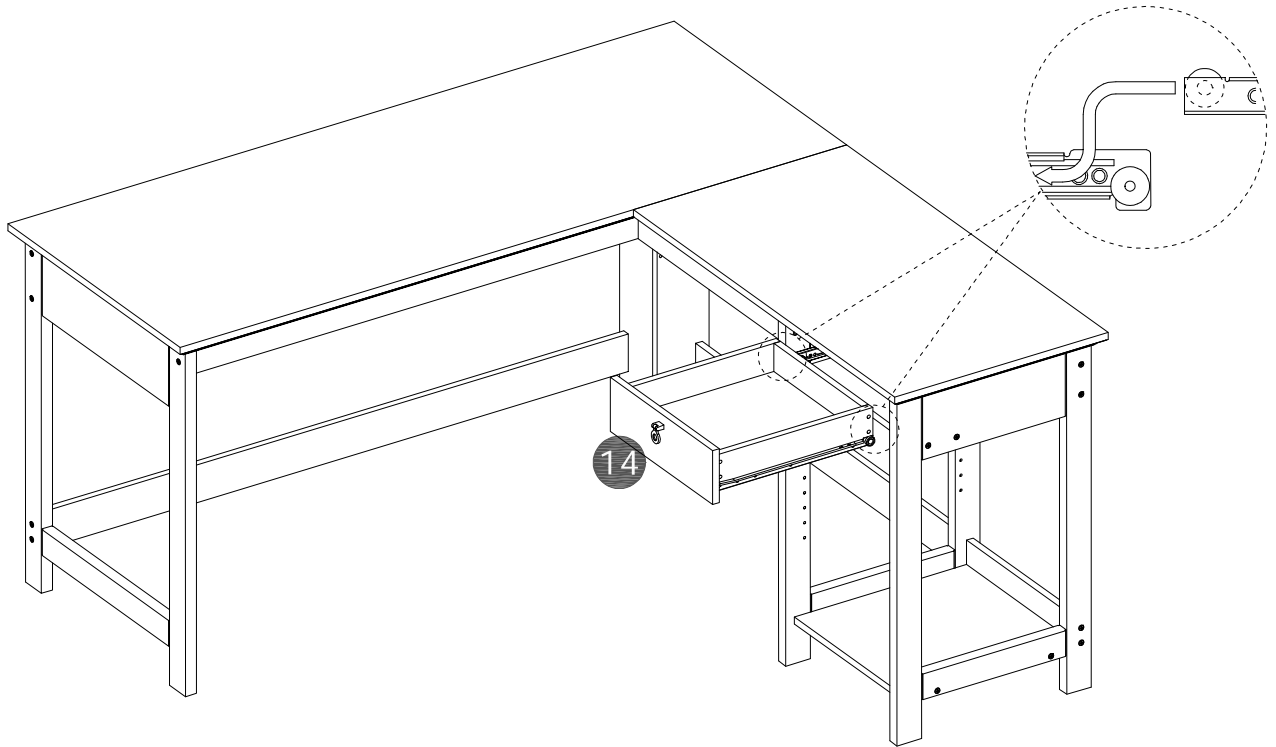

-Move unit to final location.

-Adjust drawer fronts as shown below.

Step1--Loosen screws on back of drawer front brackets as shown.

Step2--Position drawer front as required.

Step3--Tighten screws while holding drawer front in position.

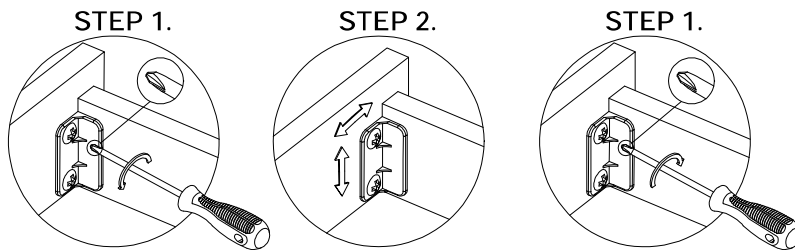

DRAWER FRONT VIEW

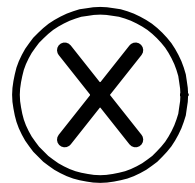
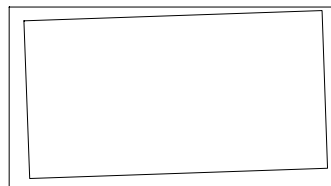
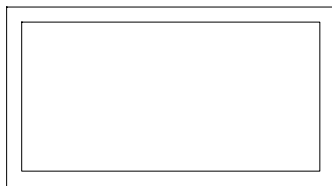

STEP 26

D x4pcs 

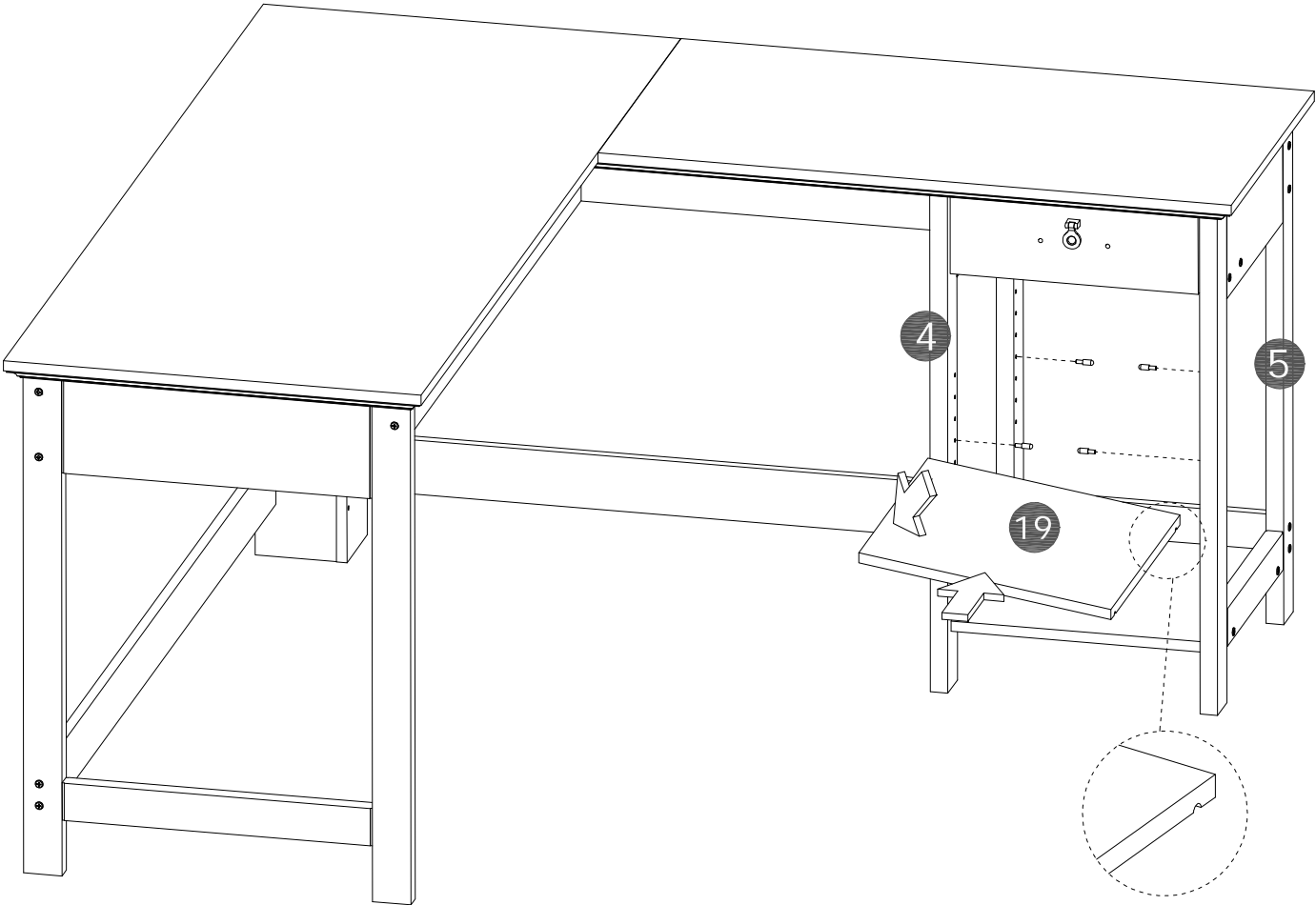
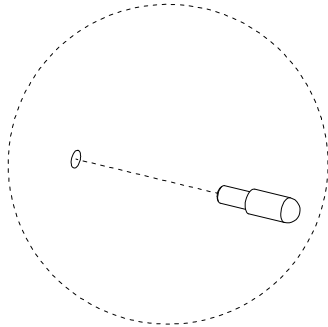

Maximum weight capacities

MAXIMUM WEIGHT: 150 LBS (68 KG)

MAXIMUM WEIGHT: 11 LBS (5 KG)

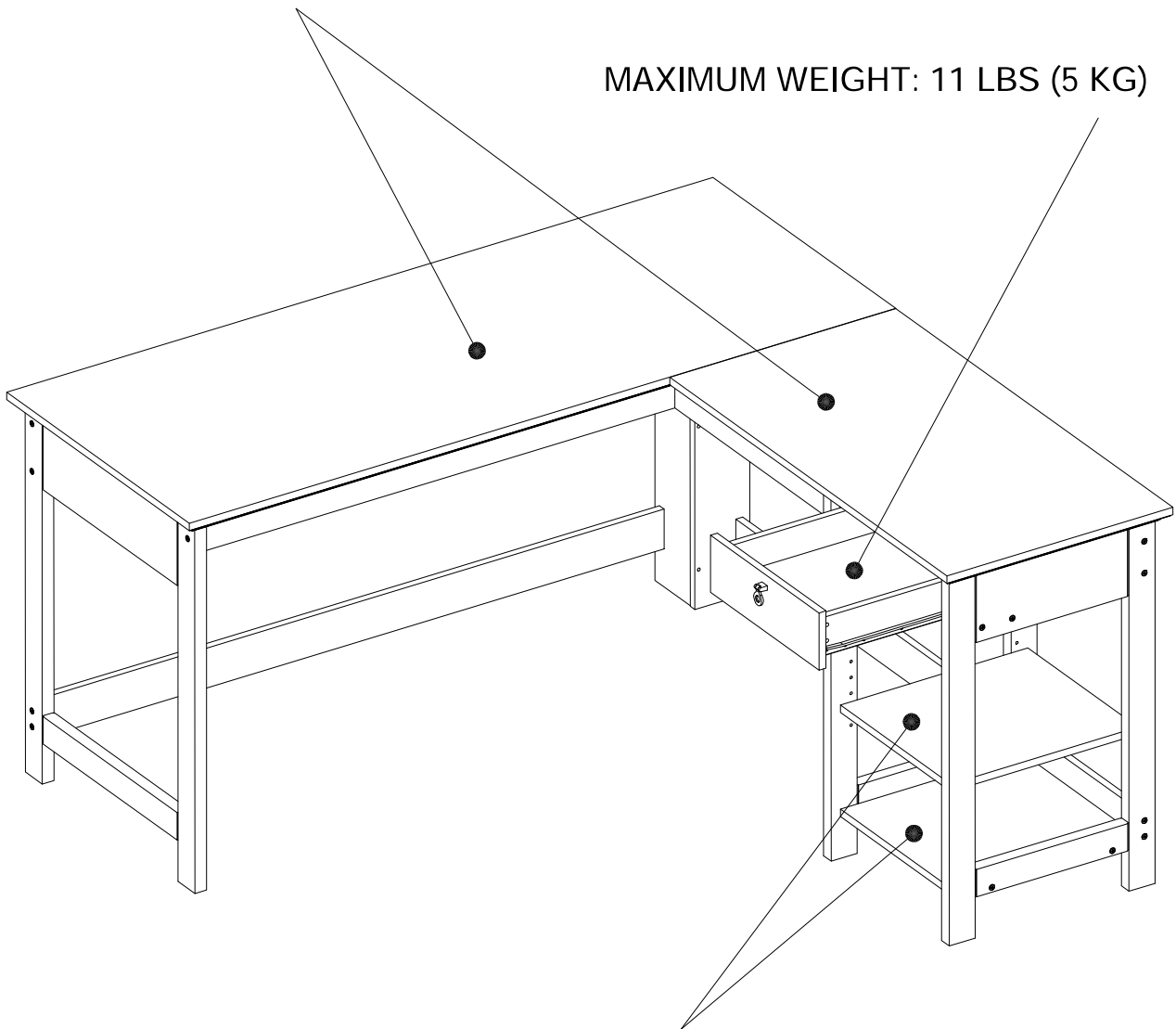

MAXIMUM WEIGHT: 22 LBS (10 KG)